

Product Specifications

Customer	
Model	NTSM215 V500



Records of Revision			
Vision	Modifying	Old Description	New Description
v2107.1	Preliminary specification		
v2107.2	Modify the Design of the Carton		
v2107.3	Correct the Dimensions		
v2107.4	New trademark released		

Features

- ★ 21.5 inch Industrial Grade Panel, 1920x1080 (FHD) Resolution
- ★ AHVA Wide Viewing Angle Technology, 178°/178°
- ★ Metal Cabinet with Diverse Combine Options
- ★ Made in Taiwan, 3 Years Warranty
- ★ Resistive/Capacitive Touch Options
- ★ Optional Video Input (VGA/DVI/HDMI/DP)
- ★ Optional 100~240VAC and 9~36VDC Power Input
- ★ Optional Software Remote Control by RS232 or DDC/CI
- ★ Optional High Brightness 1500nits, for Outdoor Environment
- ★ Optional Auto Dimming Function (with Light Sensor)
- ★ Optional AG Coating/Antibacterial/Privacy Filter Surface Treatment



PSE



BSMI



RoHS



CE



ISO9001



FCC



Desktop Stand



Wall Mounting



Open-frame Brackets



Panel Mount

Display Specifications

Model Name	NTSM215XX4XX-XXXXXX-500*	Display Mode	AHVA Mode, Normally Black
Screen Diagonal	21.5 inch	Response Time	22 msec.
Display Area	476.0x267.7 mm	Backlight Unit	LED (white LED)
Resolution	1920x1080 (FHD)	Viewing Angle (L/R, U/D)	178°/178° (CR=10)
Contrast Ratio	1000:1	Backlight Lifetime	>50,000 Hours
Display Ratio	16:9	Operating Temp.	0~50°C
Support Color	16.7M Colors	Storage Temp.	-20~60°C
Pixel Pitch	247.95x247.95 um		

* X = A~Z, 0~9 (Depends on options)

Display Options

Brightness			
	Brightness	Environment	Model Name
Standard	250nits	General (Indoor)	NTSM215NX4XX-XXXXXX-500
Option 1	1000nits	Outdoor Environment	NTSM215AX4XX-XXXXXF-500
Option 2	1500nits	Sunlight Readable	NTSM215FX4XX-XXXXXF-500

Accessories

Item	Description	Quantity
HDMI Cable	Male to Male, 1.8 Meter	1
AC-DC Adapter	12V with CE/FCC/CCC/UL/RoHS/PSE/JET Certification	1
Power Cord	*Country Specific	1
USB Cable	A type, Male to Male, 1.8 Meter *(only for touch monitor)	1

Touch Options

Resistive Touch			
Model Name	NTSM215X5400-XXXXB-500		
Touch Technology	Resistive Touch	Transparency	80%±5%
Allowed Touch Points	1 point	Surface Treatment	Anti-glare<15%
Interface	USB/RS232	Hardness	≥3H
Precision	98.50%		

Projected Capacitive Touch			
Model Name	NTSM215XP4XX-XXXXX-500		
Touch Technology	Projected Capacitive	Transparency	≥87%
Allowed Touch Points	10 points	Accuracy	99.00%
Interface	USB/RS232 (Option)	Thickness of Cover Lens	2.9±0.2mm
IK Ratings	IK07	Hardness of Cover Lens	7H

Non-Touch	
Model Name	NTSM215X04XX-XXXX0X-500

Supported OS

Windows	Win7, Win8, Win10, Win11 ↑
Linux	Kernel 2.6.24 ↑
Android	3.0 ↑
Mac	10.5.x ↑ (Intel CPU)

General Options

Video Input		
	Description	Model Name
Standard	VGA+HDMI+DP	NTSM215XX4<u>3</u>X-XXXXXX-500
Option	VGA+DVI	NTSM215XX4 <u>4</u> 1-XXXXXX-500



VGA+HDMI+DP



VGA+DVI

Power Input		
	Description	Model Name
Standard	12V, Lockable DC Jack Φ2.1mm	NTSM215XX4<u>3</u>2-XXXXXX-500
Option 1	12VDC, DC Jack Φ 2.1mm	NTSM215XX4 <u>4</u> 1-XXXXXX-500
Option 2	9~36VDC, Phoenix Terminal Block	NTSM215XX4 <u>3</u> P-XXXXXX-500
Option 3	100~240VAC, C14 Female Socket	NTSM215XX4 <u>3</u> A-XXXXXX-500



Lockable DC Power Jack

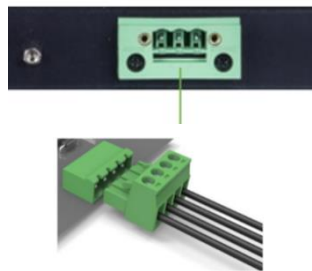

Phoenix Terminal Block



C14 AC Socket

Surface Treatment		
	Description	Model Name
Standard	(none)	NTSM215XX4XX-<u>00</u>XXXX-500
Option 1	Anti-Glare Coating	NTSM215XX4XX- <u>GG</u> XXXX-500
Option 2	Antibacterial (AB Film)	NTSM215XX4XX- <u>AB</u> XXXX-500
Option 3	Anti-Spy (AS Film)	NTSM215XX4XX- <u>SF</u> XXXX-500

General Options (Continued)

Color of Cabinet		
	Description	Model Name
Standard	Black	NTSM215XX4XX-XXBXXX-500
Option 1	White	NTSM215XX4XX-XXWXXX-500
Option 2	Silver	NTSM215XX4XX-XXSXXX-500
Options	Other Colors	NTSM215XX4XX-XXXXX-500

* X = A~Z, 0~9 (Depends on Color)

Material of Cabinet		
	Description	Model Name
Standard	SECC	NTSM215XX4XX-XXXSXX-500
Option 1	Stainless Steel	NTSM215XX4XX-XXXLXX-500
Option 2	Aluminum	NTSM215XX4XX-XXXAXX-500

Touch Interface		
	Description	Model Name
Option 1	USB+RS232 (Resistive Touch)	NTSM215X54XX-XXXXBX-500
Option 2	USB (Projected Capacitive Touch)	NTSM215XP4XX-XXXXUX-500
Option 3	RS232 (Projected Capacitive Touch)	NTSM215XP4XX-XXXXRX-500
Option 4	Non-Touch	NTSM215X04XX-XXXX0X-500

Cooling Fan		
	Description	Model Name
Standard	Fanless	NTSM215XX4XX-XXXXX0-500
Option	7 Blades/4000r.p.m/28.3dB	NTSM215XX4XX-XXXXXF-500

Input /Output System

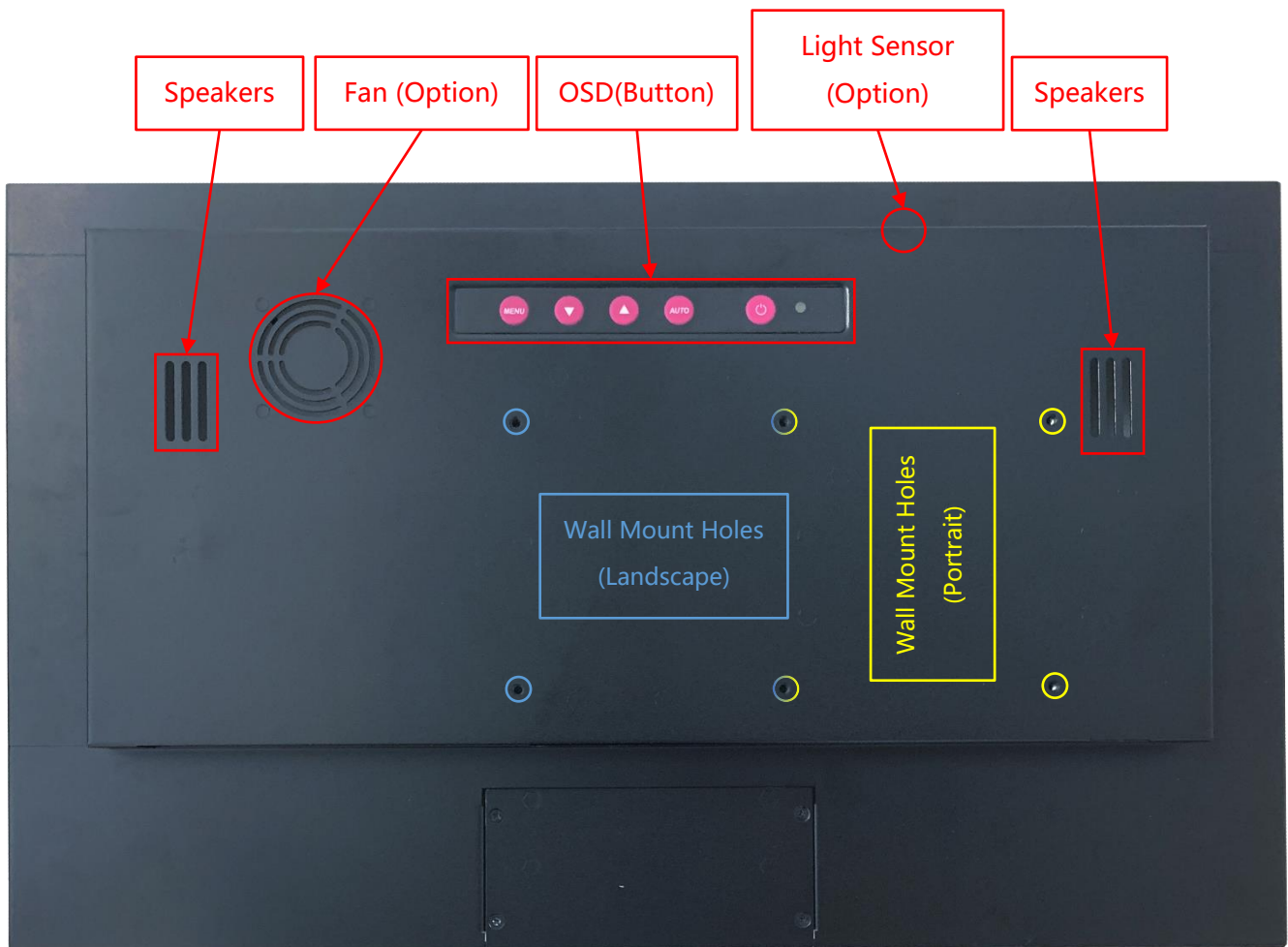
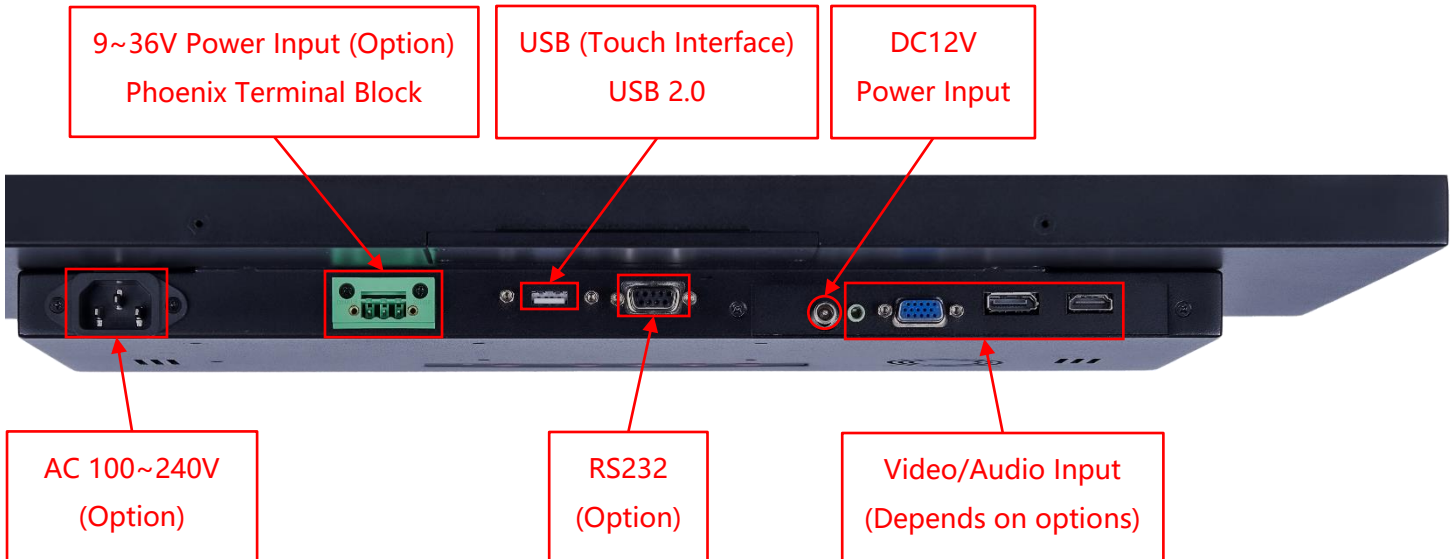

Other Options

OSD Control		
	Item	Description
Standard	Button	Rear Physical Button
Option 1	Software Remote Control	Software Remote Control by RS232/Serial Port
Option 2	Auto Dimming	Auto Brightness Adjusting by Light Sensor

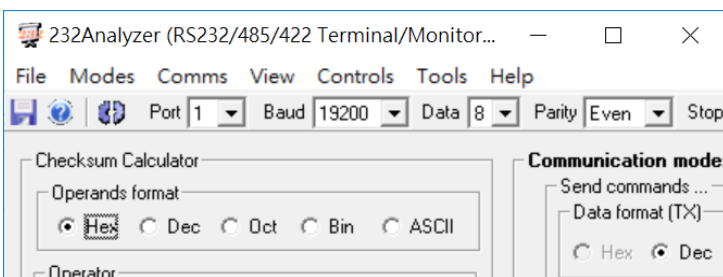

* Software Remote Control

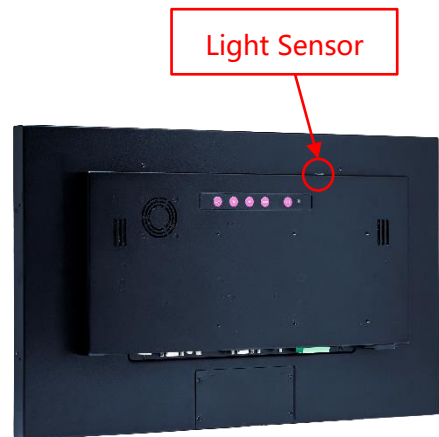

Passive Stylus Pen (Option)	
Technology	Passive High Sensitive Knitted Wire Mesh Fiber Tip
Size of tip	6mm
Magnetic Attachment	Yes



Magnetic Attachment

Desktop Stand (Option)

Item	B Stand	Part No.	DST-0B002/DST-1B002
Mounting Pattern	100x100 / 75x75 mm	Dimension (WxHxD)	203x275x227 mm
Material	Steel/Plastic/Aluminum	Net Weight	1.8 KG
Tilt (Hinge)	-2° ~ +180°	Support Max. Weight	15 KG



Item	Z Stand	Part No.	DST-0BZ01/DST-1BZ01
Mounting Pattern	100x100 / 75x75 mm	Dimension (WxHxD)	190x240x41.6
Material	SECC	Net Weight	2.6 KG
Tilt (Hinge)	±360°	Support Max. Weight	15 KG

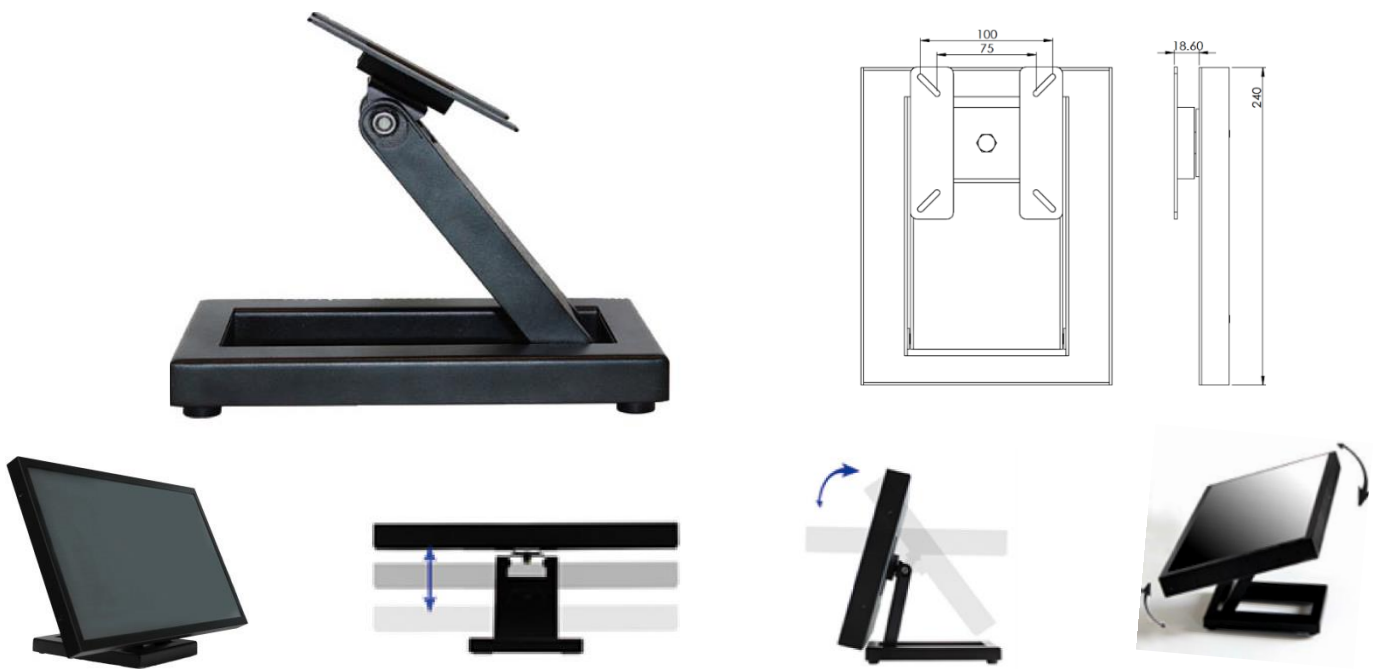

Open-frame Brackets (Option)

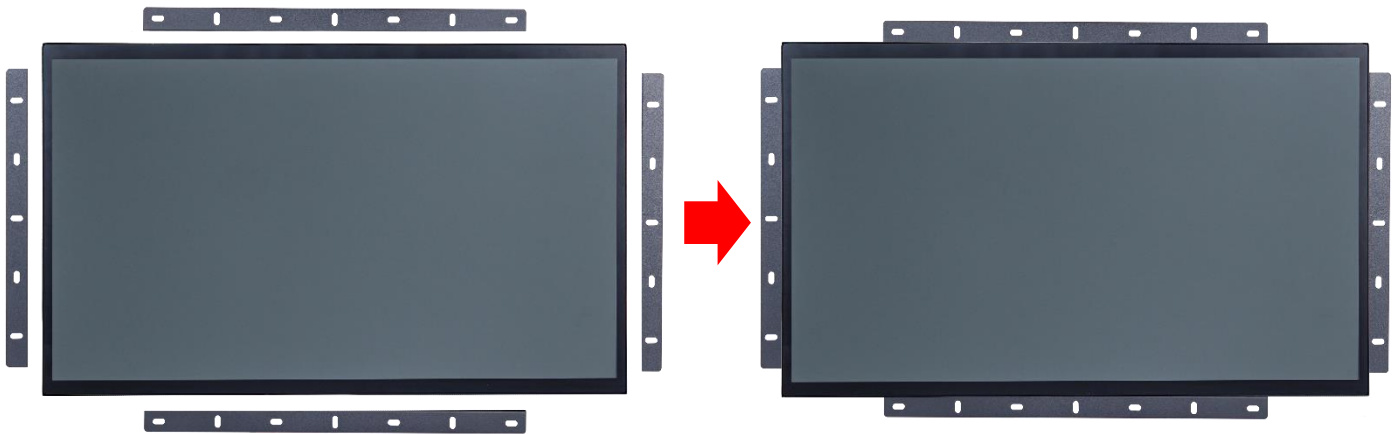

Dimension for Installing with Open-frame Brackets

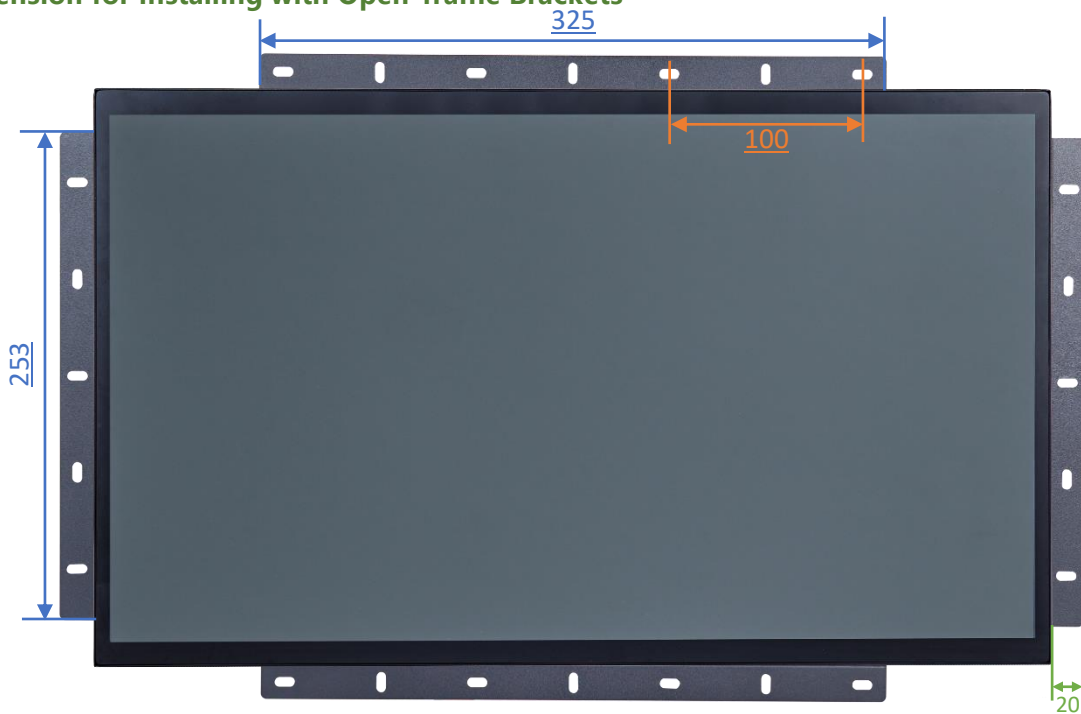

Panel Mount Kits (Option)

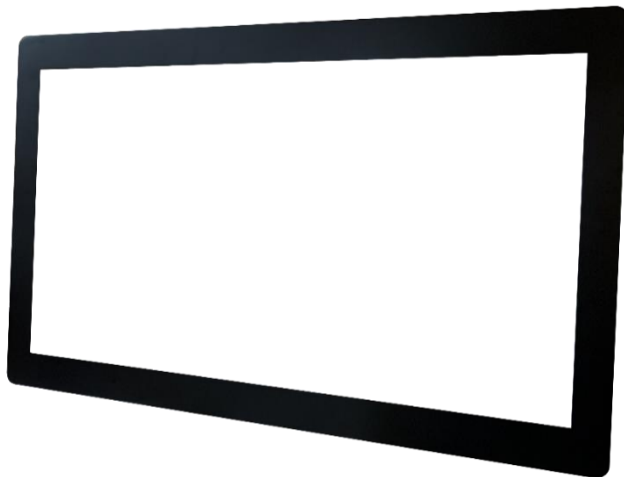

Dimension for Installing with Panel Mount Kit

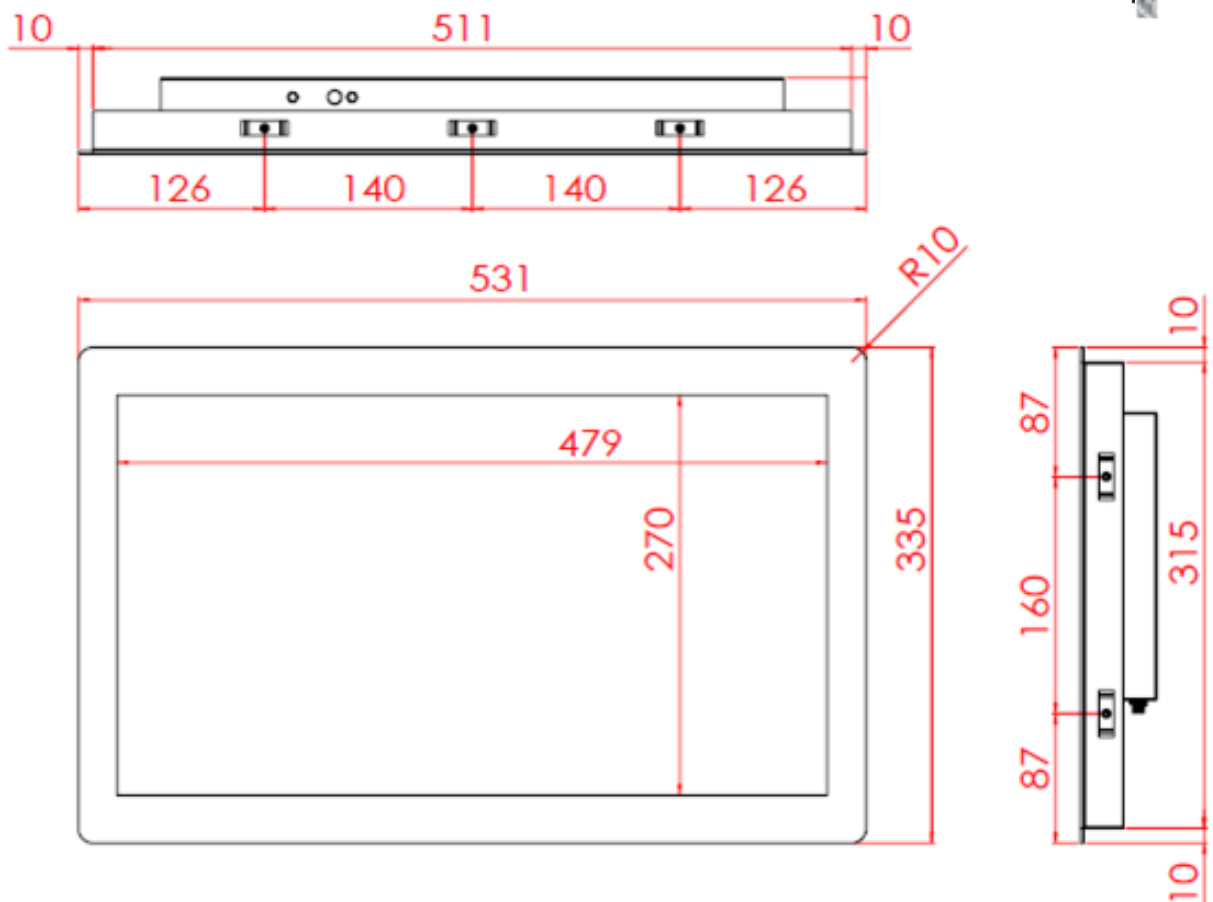



Step 1: Assemble the front module with the screen body. (This step is pre-assembled at the factory.)

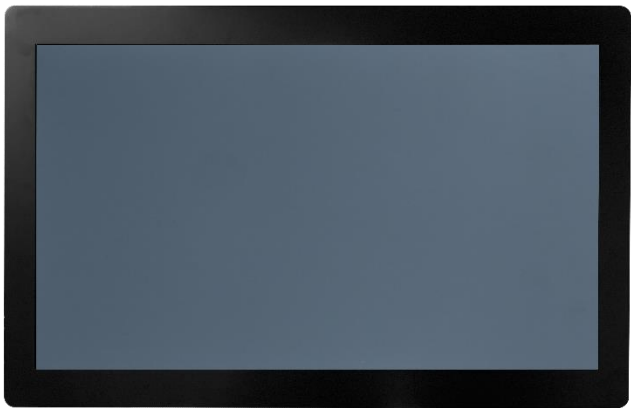
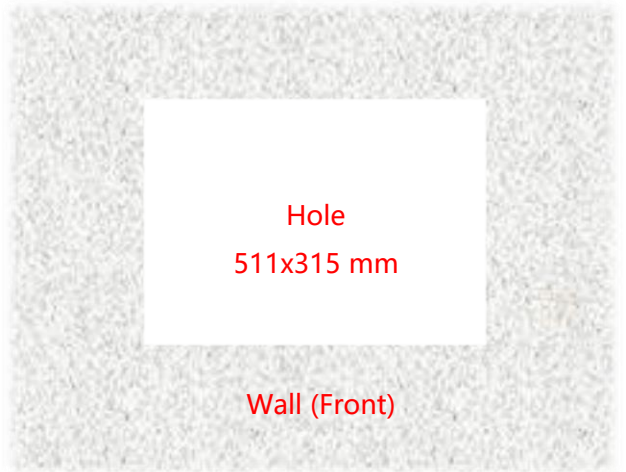

Step 2: Insert the screen from the front into the pre-cut opening.

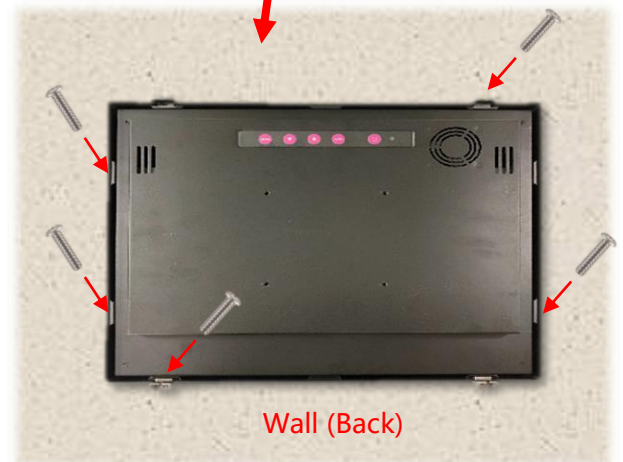

Step 3: Attach the clips from the back and secure with screws. (Up to 10 clips can be installed as needed or per positional limitations.)

Wall Mount Bracket (Option)

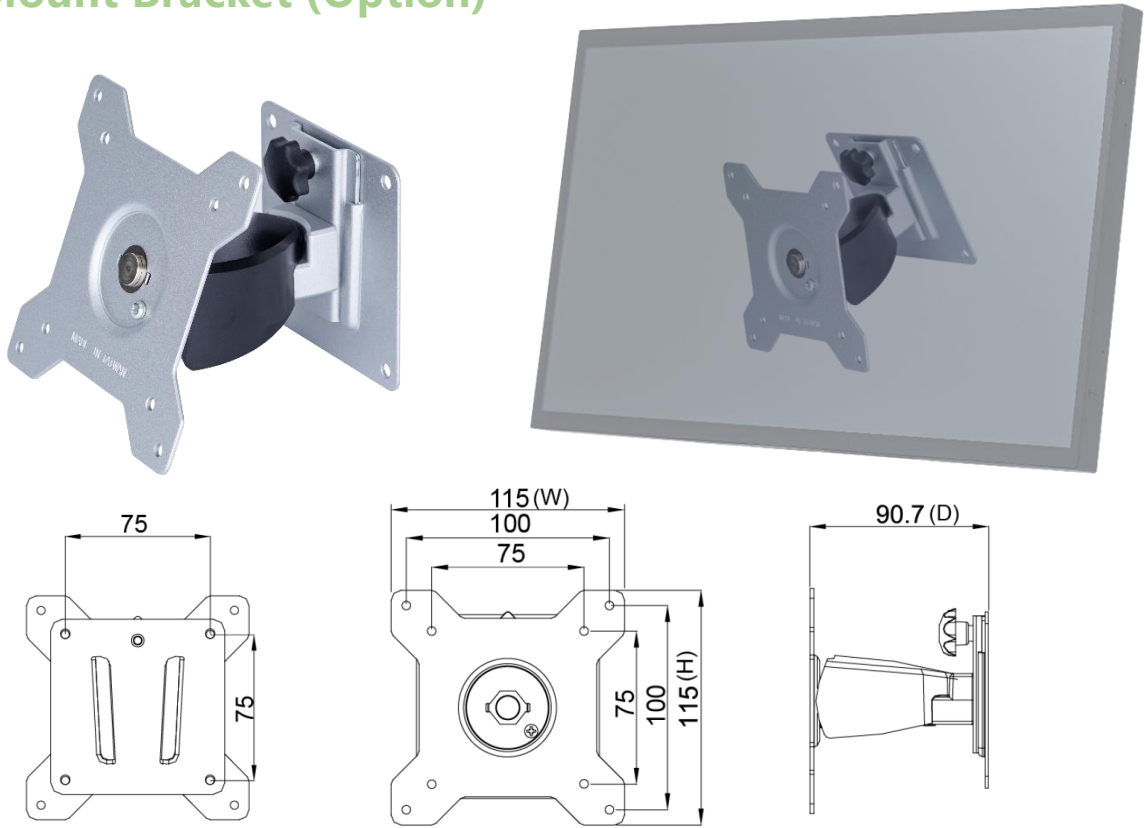

Packing Information



Unit Carton Size	677x161x440 mm
Unit N. Weight	≤4.8 KG
Unit G. Weight	≤6.9 KG
Units per Pallet	30 units
Pallet Size	120x100x147 CM

Physical Specifications

Dimension (Max)	504x308x50(±2)mm	Net Weight	≤4.8 KG
VESA Mounting	100x100 mm	Gross Weight	≤6.8 KG

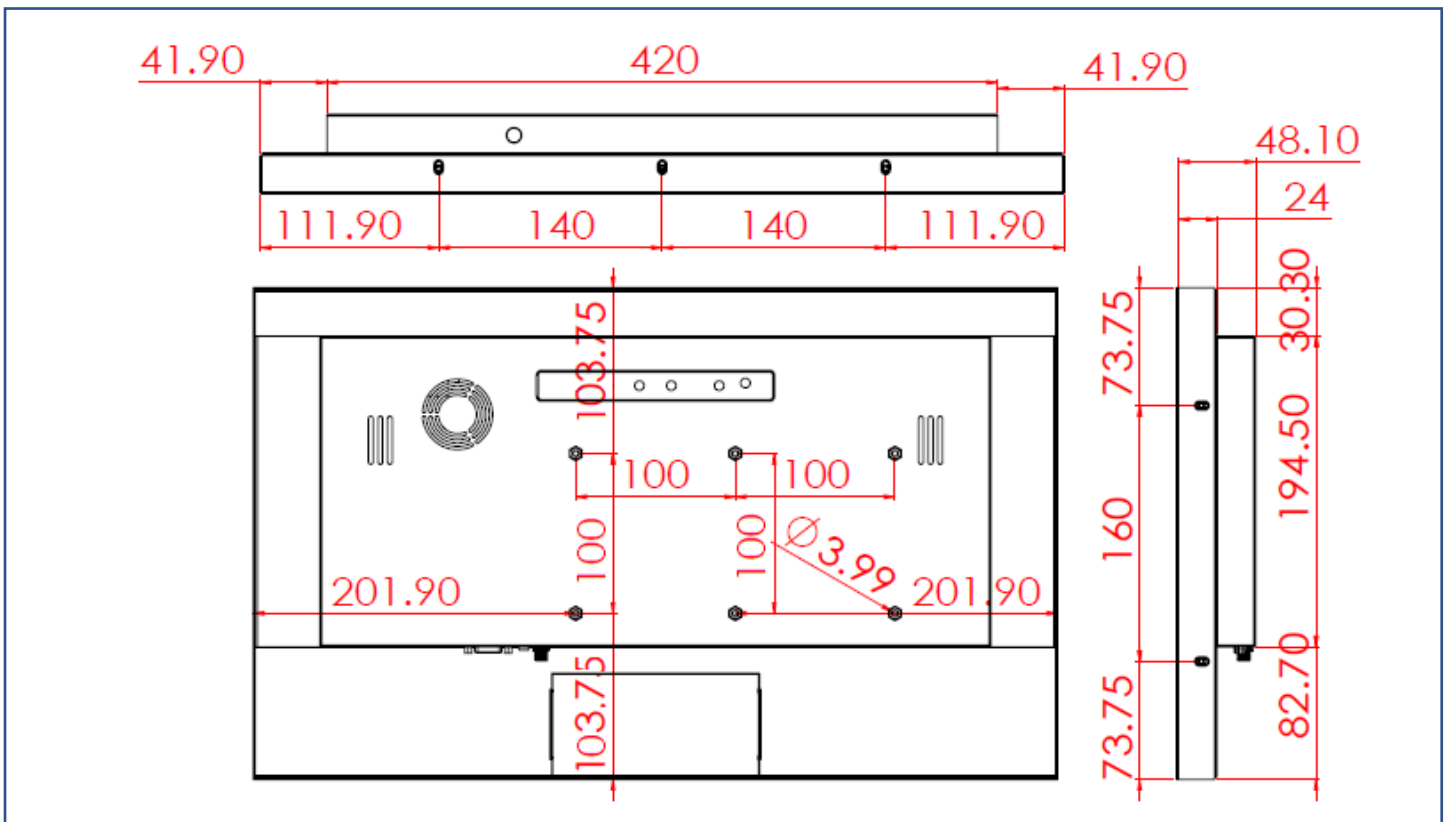
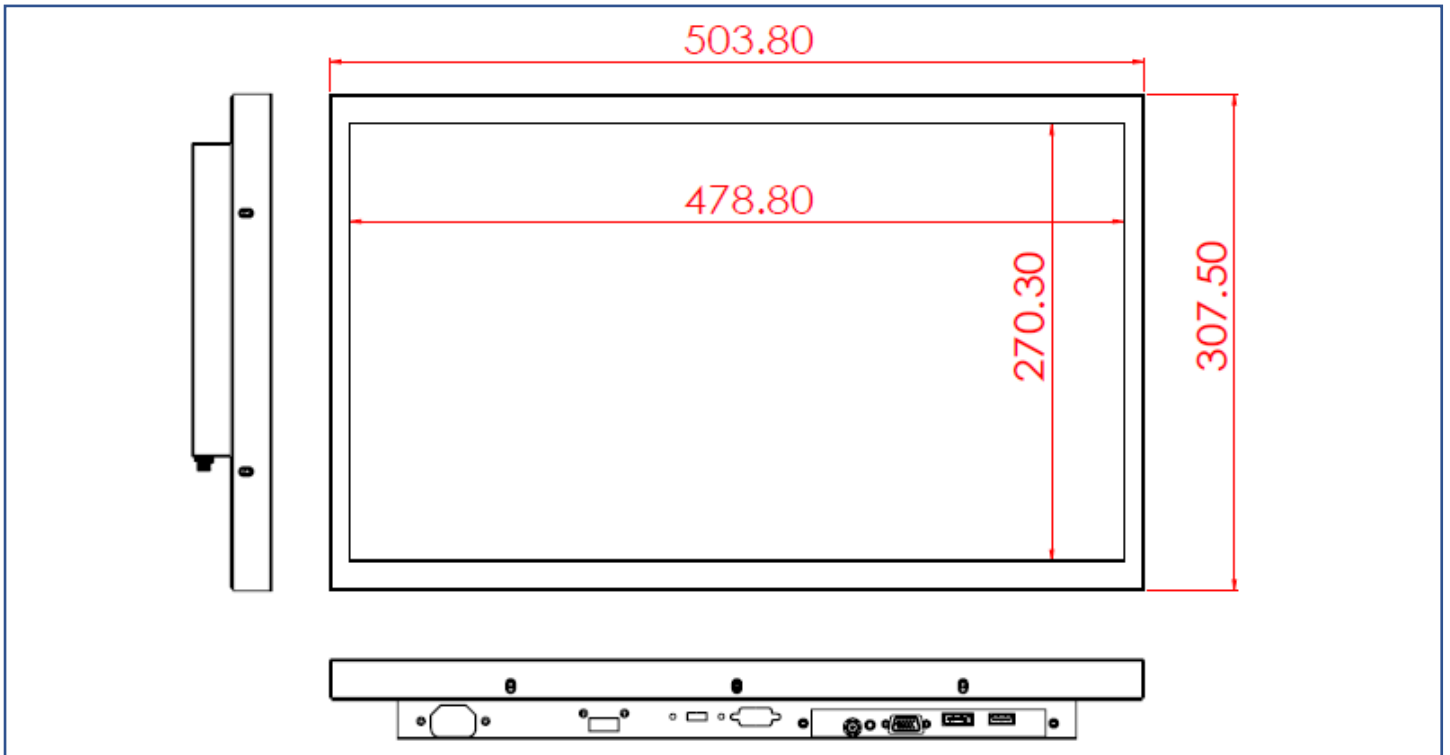

Cosmetic Inspection Standard

Display Area Allowance			
Defect description	Defective Specifications	Allowance	Remarks
Dot Defect (including dark dot, particles, bubbles, pits, dust, foreign matter)	$D \leq 0.2\text{mm}$	Ignored	D=Diameter
	$0.2 < D \leq 0.7\text{mm}$	$N \leq 5$	N=Quantity
	$0.7 < D \leq 1\text{mm}$	$N \leq 3$	
	$D > 1\text{mm}$	$N \leq 0$	
Linear Defect (including scratches, fluff, particles)	$W \leq 0.15\text{mm}$	Ignored	W=Width
	$0.15 < W \leq 0.5\text{mm}, L \leq 15\text{mm}$	$N \leq 2$	L=Length
	$W > 0.5\text{mm}$ or $L > 15\text{mm}$	NG	

* Visual inspection distance: 60cm, 90 degree (same for front/side/back)

Front Appearance Allowance (Including Coating)			
Defect description	Defective Specifications	Allowance	Remarks
Dot Defect (including particles, bubbles, pits...etc.)	$D \leq 0.7\text{mm}$	Ignored	D=Diameter
	$0.7 < D \leq 1.5\text{mm}$	$N \leq 3$	N=Quantity
	$D > 1.5\text{mm}$	$N \leq 0$	
Linear Defect (including scratches, fluff, particles)	$W \leq 0.2\text{mm}, L \leq 15\text{mm}$	Ignored	W=Width, L=Length
	$0.2 < W \leq 0.7\text{mm}, L \leq 15\text{mm}$	$N \leq 1$	
	$W > 0.7\text{mm}$ or $L > 15\text{mm}$	NG	

Side / Back Appearance Allowance (Including Coating)			
Defect description	Defective Specifications	Allowance	Remarks
Dot Defect (including particles, bubbles, pits...etc.)	$D \leq 1.5\text{mm}$	Ignored	D=Diameter
	$1.5 < D \leq 3\text{mm}$	$N \leq 8$	N=Quantity
	$D > 3\text{mm}$	$N \leq 2$	
Linear Defect (including scratches, fluff, particles)	$W \leq 0.8\text{mm}, L \leq 15\text{mm}$	Ignored	W=Width, L=Length
	$0.8 < W \leq 1.5\text{mm}, L \leq 15\text{mm}$	$N \leq 5$	
	$W > 1.5\text{mm}$ or $L > 15\text{mm}$	NG	

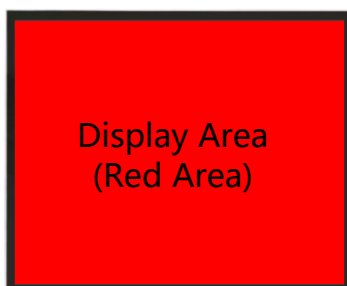

Display Area
(Red Area)



Front Appearance (Red Area)



Back Appearance