

Product Specifications

Customer	
Model	NTOD150 V500



Records of Revision			
Vision	Modifying	Old Description	New Description
v2409.1	Preliminary Specification		

Nextech OD Series 15" Industrial Waterproof Touch Monitor

NTOD150 V500

Features

- ★ 15 inch Industrial Grade Panel, 1024x768 Resolution
- ★ IAV Wide Viewing Angle Technology , 176°/176°
- ★ Operating Temperature Range -30~80°C
- ★ IP68/69K Level Waterproof Enclosure
- ★ Stainless Steel Cabinet
- ★ AG Coating Surface Treatment
- ★ HDMI Video Input
- ★ Optional Resistive/Capacitive Touch Options
- ★ Optional High Brightness 1500nits, for Outdoor Environment
- ★ Optional Auto Dimming Function (with Light Sensor)
- ★ Made in Taiwan, 3 Years Warranty, Designed for Harsh Environments



PSE



BSMI



ISO9001



FCC



Nextech OD Series 15" Industrial Waterproof Touch Monitor

NTOD150 V500

Display Specifications

Model Name	NTOD150XX2DA-GGSLX0-500*	Display Mode	IAV Mode, Normally Black
Screen Diagonal	15.0 inch	Response Time	18 msec.
Display Area	304.1x228.1 mm	Backlight Unit	LED (white LED)
Resolution	1024x768	Viewing Angle (L/R, U/D)	176°/176°
Contrast Ratio	2500:1	Backlight Lifetime	>70,000 Hours
Display Ratio	4:3	Operating Temp.	-30~80°C
Support Colors	16.7M Colors	Storage Temp.	-40~85°C
Pixel Pitch	297x297 um		

* X = A~Z, 0~9 (Depends on options)

Display Options

Brightness			
	Brightness	Environment	Model Name
Standard	500nits	General (Indoor)	NTOD150NX2DA-GGSLX0-500
Option 1	1000nits	Outdoor Environment	NTOD150AX2DA-GGSLX0-500
Option 2	1500nits	Sunlight Readable	NTOD150FX2DA-GGSLX0-500

Accessories

Item	Description	Quantity
HDMI Cable	HDMI Waterproof Connector, 2M	1
USB Cable	USB 3.0 Waterproof Connector, 2M	1
Power cord	*Country Specific	1

Touch Options

Projected Capacitive			
Model Name	NTOD150X <u>P</u> 2DA-GGSL <u>U</u> 0-500		
Touch Technology	Projected Capacitive	Transparency	≥87%
Allowed Touch Points	10 points	Surface Treatment	AG Coating
Transparency	USB	Thickness of Cover Lens	2.0±0.2mm
IK Ratings	IK07	Hardness of Cover Lens	7H

Resistive			
Model Name	NTOD150X <u>5</u> 2DA-GGSL <u>U</u> 0-500		
Touch Technology	Resistive	Transparency	80%±5%
Allowed Touch Points	Single point	Surface Treatment	AG Coating
Transparency	USB	Hardness of Cover Lens	≥3H

Non-Touch	
Model Name	NTOD150X <u>0</u> 2DA-GGSL <u>0</u> 0-500

Supported OS

Windows	Win7, Win8, Win10, Win11 ↑
Linux	Kernel 2.6.24 ↑
Android	3.0 ↑
Mac	10.5.x ↑ (Intel CPU)

Input /Output System



Nextech OD Series 15" Industrial Waterproof Touch Monitor

NTOD150 V500

Desktop Stand (Option)

Item	B Stand	Part No.	DST-0B002/DST-1B002
Mounting Pattern	100x100 / 75x75 mm	Dimension (WxHxD)	203x275x227 mm
Material	Steel/Plastic/Aluminum	Net Weight	1.8 KG
Tilt (Hinge)	-2° ~ +180°	Support Max. Weight	15 KG



Wall Mount Bracket (Option)

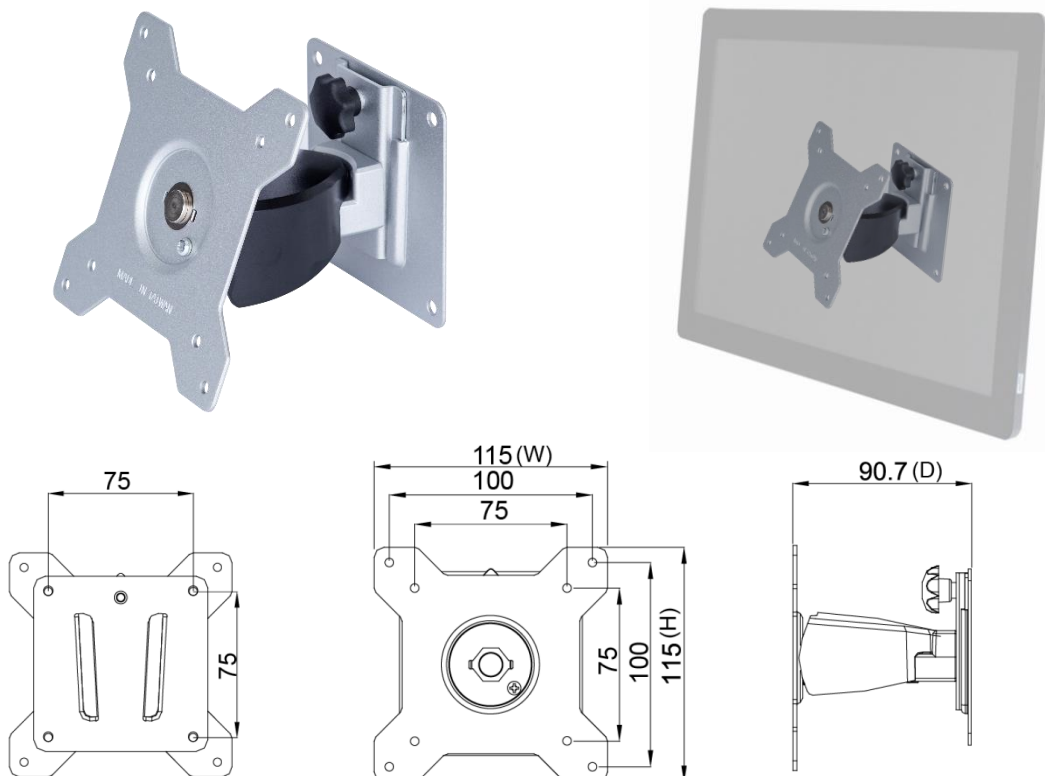

Packing Information

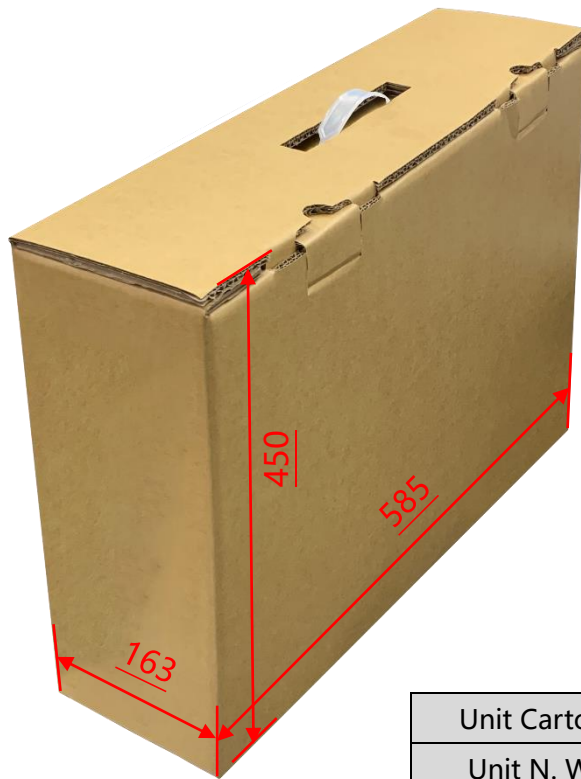

Unit Carton Size	585x163x450 mm
Unit N. Weight	≤3.8 KG
Unit G. Weight	≤5.3 KG
Units per Pallet	36 units
Pallet Size	120x100x147 CM

Physical Specifications

Dimension (Max)	339.6x263.6x54(±2)mm	Net Weight	≤3.8 KG
VESA Mounting	75x75/100x100 mm	Gross Weight	≤5.3 KG

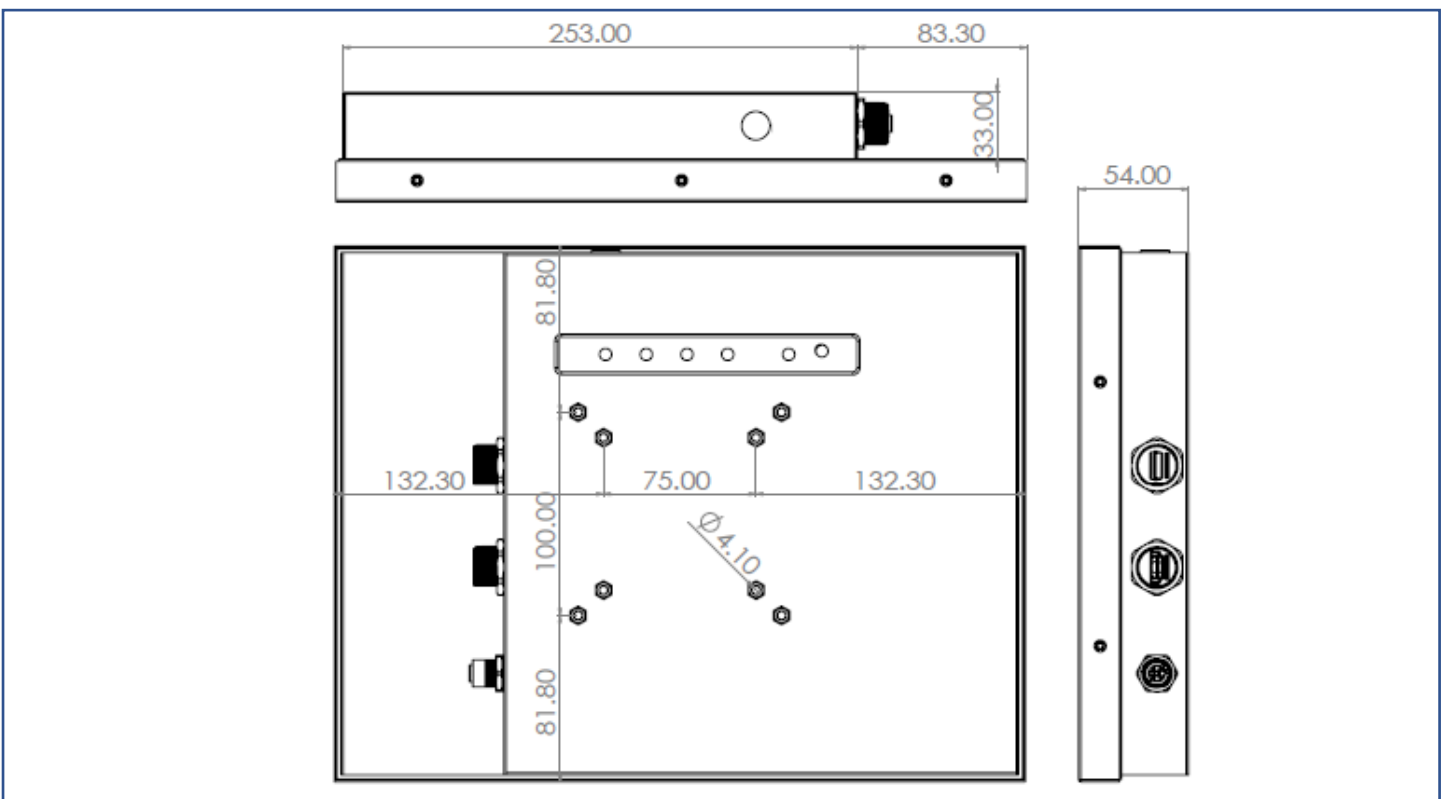
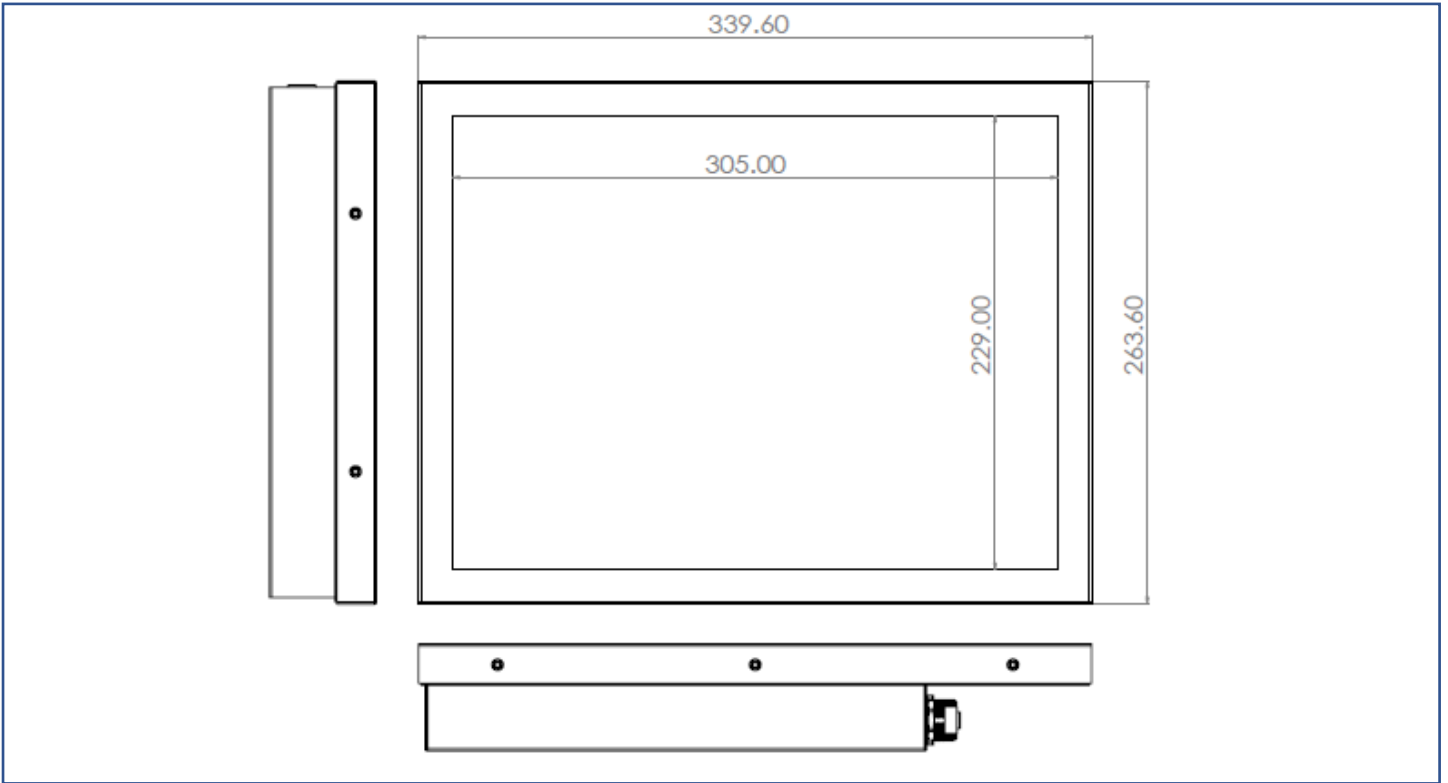

Cosmetic Inspection Standard

Display Area Allowance			
Defect description	Defective Specifications	Allowance	Remarks
Dot Defect (including dark dot, particles, bubbles, pits, dust, foreign matter)	$D \leq 0.2\text{mm}$	Ignored	D=Diameter
	$0.2 < D \leq 0.7\text{mm}$	$N \leq 5$	N=Quantity
	$0.7 < D \leq 1\text{mm}$	$N \leq 3$	
	$D > 1\text{mm}$	$N \leq 0$	
Linear Defect (including scratches, fluff, particles)	$W \leq 0.15\text{mm}$	Ignored	W=Width
	$0.15 < W \leq 0.5\text{mm}, L \leq 15\text{mm}$	$N \leq 2$	L=Length
	$W > 0.5\text{mm}$ or $L > 15\text{mm}$	NG	

* Visual inspection distance: 60cm, 90 degree (same for front/side/back)

Front Appearance Allowance (Including Coating)			
Defect description	Defective Specifications	Allowance	Remarks
Dot Defect (including particles, bubbles, pits...etc.)	$D \leq 0.7\text{mm}$	Ignored	D=Diameter
	$0.7 < D \leq 1.5\text{mm}$	$N \leq 3$	N=Quantity
	$D > 1.5\text{mm}$	$N \leq 0$	
Linear Defect (including scratches, fluff, particles)	$W \leq 0.2\text{mm}, L \leq 15\text{mm}$	Ignored	W=Width, L=Length
	$0.2 < W \leq 0.7\text{mm}, L \leq 15\text{mm}$	$N \leq 1$	
	$W > 0.7\text{mm}$ or $L > 15\text{mm}$	NG	

Side / Back Appearance Allowance (Including Coating)			
Defect description	Defective Specifications	Allowance	Remarks
Dot Defect (including particles, bubbles, pits...etc.)	$D \leq 1.5\text{mm}$	Ignored	D=Diameter
	$1.5 < D \leq 3\text{mm}$	$N \leq 8$	N=Quantity
	$D > 3\text{mm}$	$N \leq 2$	
Linear Defect (including scratches, fluff, particles)	$W \leq 0.8\text{mm}, L \leq 15\text{mm}$	Ignored	W=Width, L=Length
	$0.8 < W \leq 1.5\text{mm}, L \leq 15\text{mm}$	$N \leq 5$	
	$W > 1.5\text{mm}$ or $L > 15\text{mm}$	NG	



Display Area
(Red Area)



Front Appearance (Red Area)



Back Appearance