

Product Specifications

Customer	
Model	NTAP190-2 V500
Name	NTAP190<u>XX2XX</u>-J8A72F8-<u>XXXX</u>-500

* X = A~Z, 0~9 (Depends on Options.)

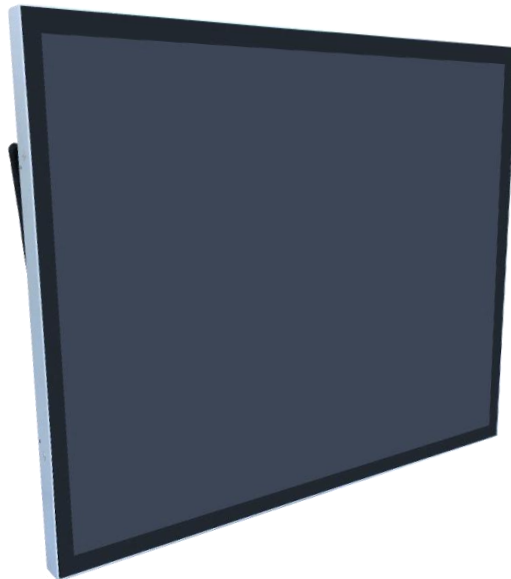

Records of Revision			
Vision	Modifying	Old Description	New Description
v2012.1	Preliminary Specification		
v2012.2	Add the Panel Mount Kits Option		
v2012.3	Add Stylus Pen Option		
v2012.4	New trademark released		

Features

- ★ 19 inch Industrial Grade Panel, 1280x1024 Resolution
- ★ Wide Operating Temperature Range -30~85°C
- ★ Rock Chip ARM Cortex A17 RK3288 Quad-Core 1.8GHz CPU
- ★ On Board DDR3-1333 2G RAM (Max. upgraded to 4G)
- ★ On Board 8G Flash ROM (Max. upgraded to 32G)
- ★ Micro SD Card Slot x1 (Max. to 64G)
- ★ Android 9.0
- ★ Narrow Bezel, True Flat Projected Capacitive Touch Screen
- ★ 7H Hardness Tempered Cover Glass
- ★ 10 points Multi-touch, Supports NEXTECH Dedicated Stylus
- ★ Metal Cabinet with Diverse Combine Options
- ★ Made in Taiwan, 3 Years Warranty, Designed for Harsh Environments
- ★ Optional High Brightness 1500nits, for Outdoor Environment
- ★ Optional AG Coating/Antibacterial/Privacy Filter Surface Treatment



PSE



BSMI



CE



ISO9001



FCC

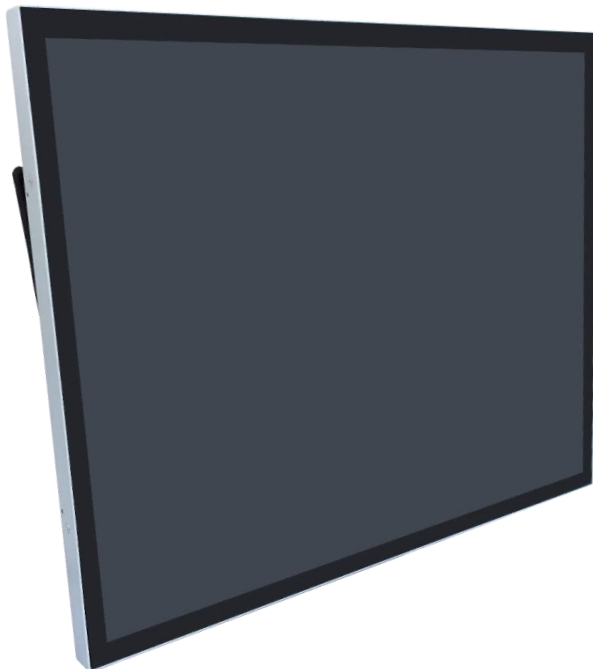

Desktop Stand



Wall Mounting



Open-frame Bracket



Panel Mount

System Specifications

CPU	Rock Chip ARM Cortex A17 RK3288 Quad-Core 1.8GHz
Memory	DDR3-1333 2G
Storage	8G Flash ROM (Max. to 32G)
GPU Chip	Mali T764 GPU
Sound Chip	ES8316 2 Channel HD Audio
Physical Network	Realtek RTL8211E-CB Gbe (RJ45)
Wireless Network	Realtek RTL8723BS 802.11b/g/n 2.4G WIFI and Blue Tooth v4.0
Hardware Monitoring	RJ45 10/100 Mbps, WIFI 802.11b/g/n
OS	Android 9.0

Display Specifications

Screen Diagonal	482.6 mm (19.0 inch)	Display Mode	TN Mode, Normally White
Display Area	376.3x301.1 mm	Backlight Unit	LED (white LED)
Resolution	1280x1024 (SXGA)	Viewing Angle (L/R, U/D)	170°/160°
Contrast Ratio	1000:1	Response Time	10 msec.
Display Ratio	4:3	Backlight Lifetime	>50,000 Hours
Support Colors	16.7M Colors	Operating Temp.	-30~85°C
Pixel Pitch	0.294x0.294 mm	Storage Temp.	-30~85°C

Display Options

Brightness			
	Brightness	Environment	Model Name
Standard	350nits	General (Indoor)	NTAP190NX2XX-J8A72F8-XXXX-500
Option 1	1000nits	Outdoor Environment	NTAP190AX2XX-J8A72F8-XXFX-500
Option 2	1500nits	Sunlight Readable	NTAP190FX2XX-J8A72F8-XXFX-500

Touch Options

Projected Capacitive			
Model Name	NTAP190X <u>P2XX</u> -J8A72F8- <u>XXXX</u> -500		
Touch Technology	Projected Capacitive	Thickness of Cover Lens	1.8±0.2mm
Allowed Touch Points	10 points	Hardness of Cover Lens	7H
Transparency	≥87%	IK Ratings	IK07
Accuracy	99.00%		

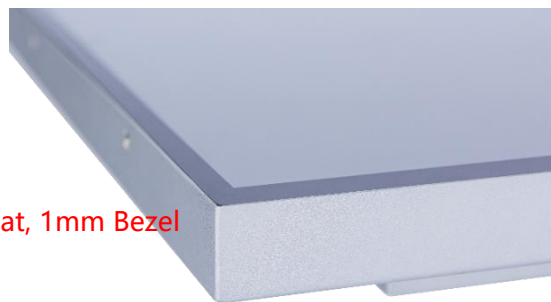

* True Flat, 1mm Bezel

Non-Touch	
Model Name	NTAP190X <u>02XX</u> -J8A72F8- <u>XXXX</u> -500

Surface Treatment		
	Description	Model Name
Standard	(none)	NTAP190XX2<u>00</u>-J8A72F8-<u>XXXX</u>-500
Option 1	Anti-Glare Coating	NTAP190XX2 <u>GG</u> -J8A72F8- <u>XXXX</u> -500
Option 2	Antibacterial (AB Film)	NTAP190XX2 <u>AB</u> -J8A72F8- <u>XXXX</u> -500
Option 3	Anti-Spy (AS Film)	NTAP190XX2 <u>SF</u> -J8A72F8- <u>XXXX</u> -500

Passive Stylus Pen (Option)	
Technology	Passive High Sensitive Knitted Wire Mesh Fiber Tip
Size of tip	6mm
Magnetic Attachment	Yes

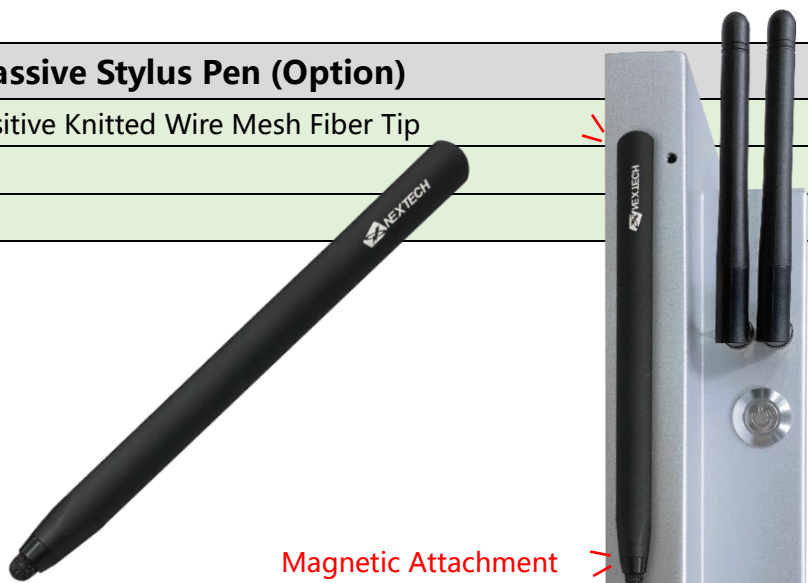

Magnetic Attachment

System Options

Material of Cabinet		
	Description	Model Name
Standard	SECC	NTAP190XX2XX-J8A72F8-SXXX-500
Option 1	Stainless Steel	NTAP190XX2XX-J8A72F8-LXXX-500
Option 2	Aluminum	NTAP190XX2XX-J8A72F8-AXXX-500

Color of Cabinet		
	Description	Model Name
Standard	Silver	NTAP190XX2XX-J8A72F8-XSXX-500
Option 1	White	NTAP190XX2XX-J8A72F8-XWXX-500
Option 2	Black	NTAP190XX2XX-J8A72F8-XBXX-500
Options	Other Color	NTAP190XX2XX-J8A72F8-XXX-500

* X = A~Z, 0~9 (Depends on Color)

Cooling Fan		
	Description	Model Name
Standard	7 Blades/4000r.p.m/28.3dB	NTAP190XX2XX-J8A72F8-XXFX-500
Option	Fanless	NTAP190XX2XX-J8A72F8-XX0X-500

Power Input		
	Description	Model Name
Standard	12VDC-in, with AC/DC Adapter	NTAP190XX2XX-J8A72F8-XXX2-500
Option	100~240VAC, C14 AC Power Socket	NTAP190XX2XX-J8A72F8-XXXA-500



DC-in



AC-in

Input /Output System

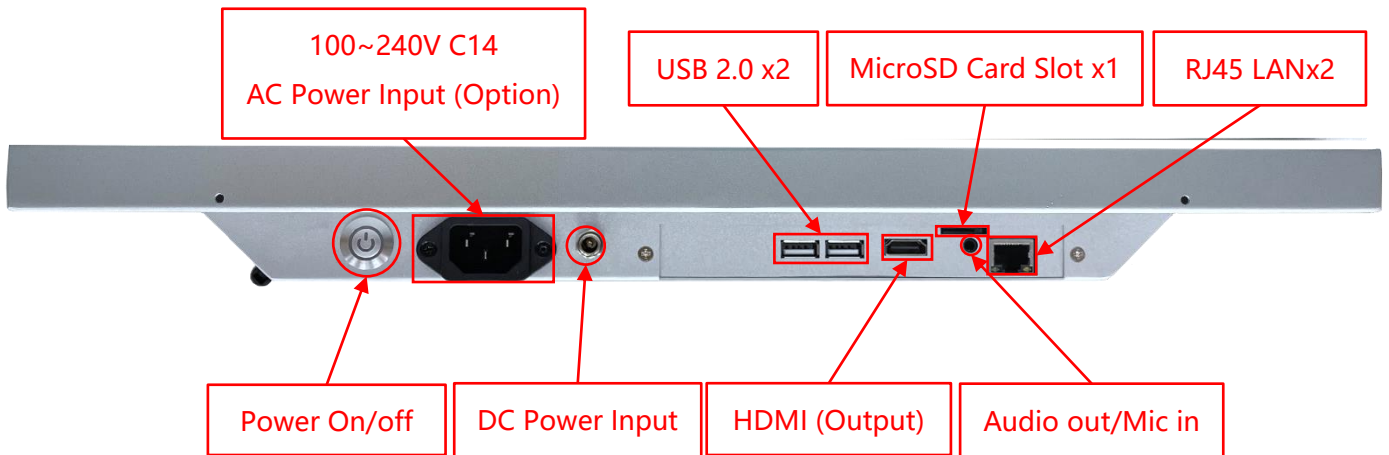

Input / Output	Connectors	Input / Output	Connectors
HDMI (Output)	1	USB 2.0	2
Audio Output /Mic Input (3.5mm)	1	MicroSD Card Slot	1
DC Power Input	1	LAN (RJ45)	1
AC Power Input	Option	Wi-Fi/Bluetooth & Antenna	1
Speakers	2W x2		

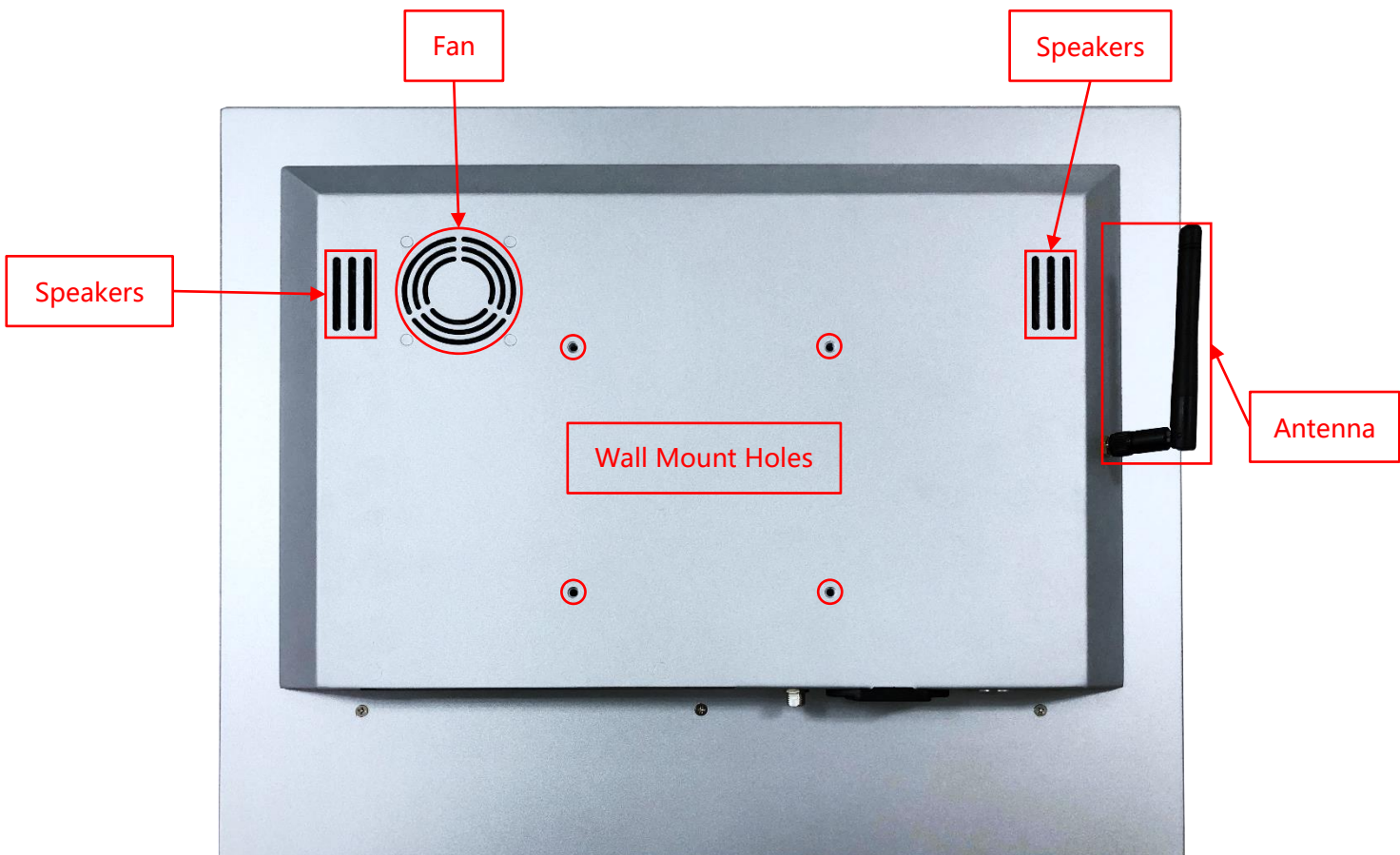

Front Cover (Option)

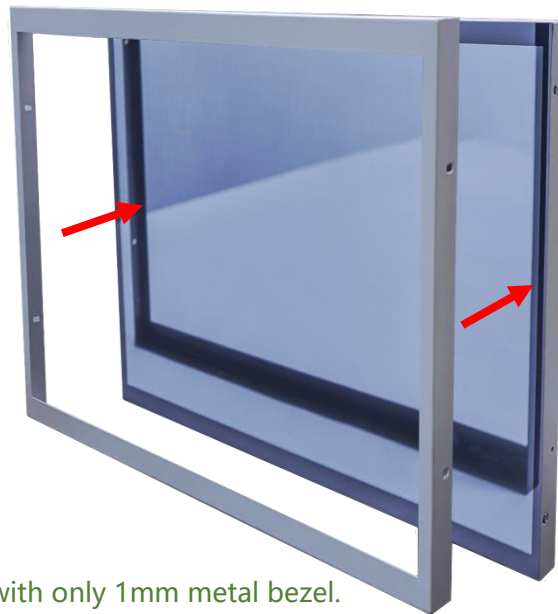

The standard **NTAP190** is true flat surface, with only 1mm metal bezel.
To protect the corners of the touch screen, the **Front Cover** can be added.



The watertight gasket can be added between the **Front Cover** and **NTAP190**.
It complies **IP65** on front.

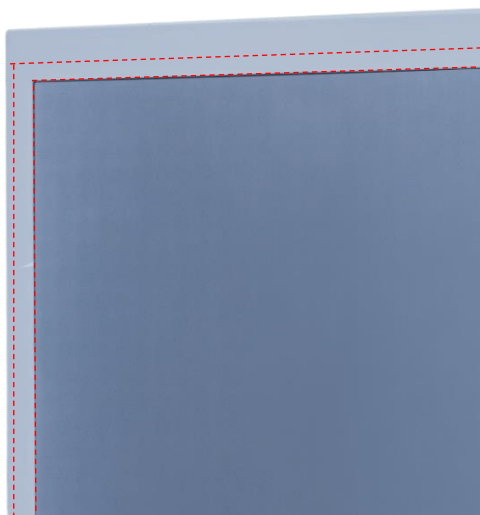

Open-frame Brackets (Option)

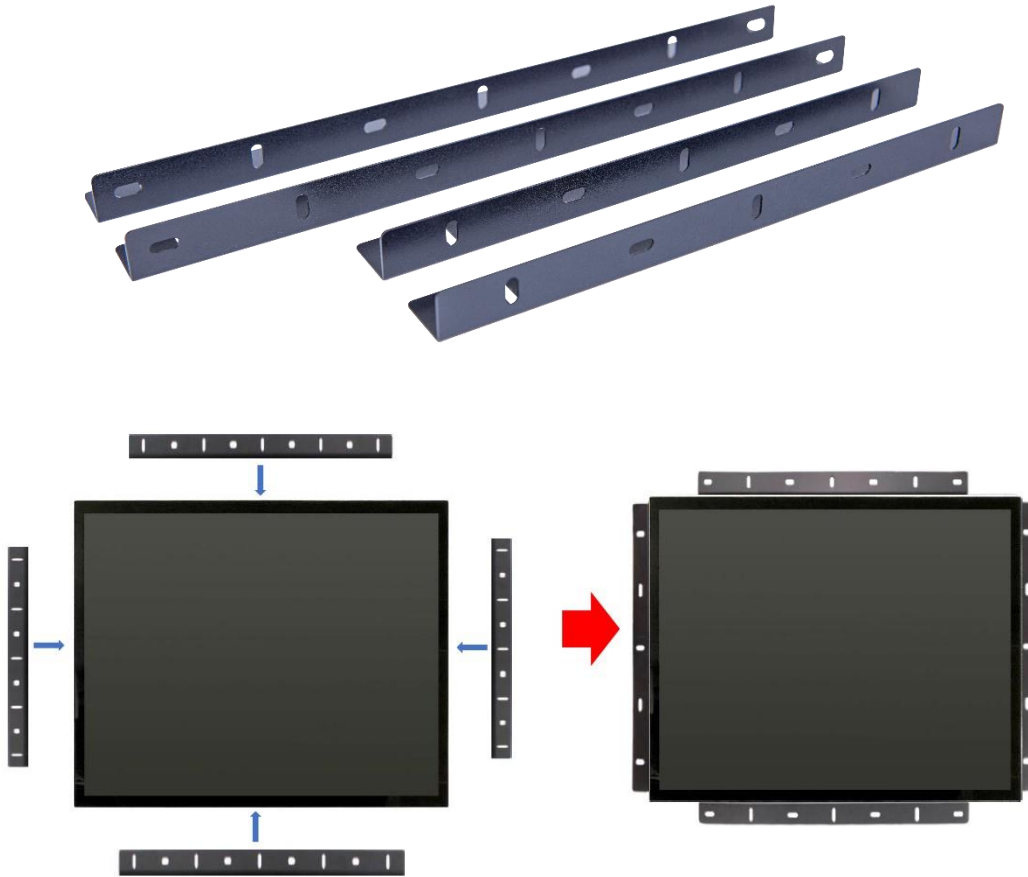

Dimension for Installing with Open-frame Brackets

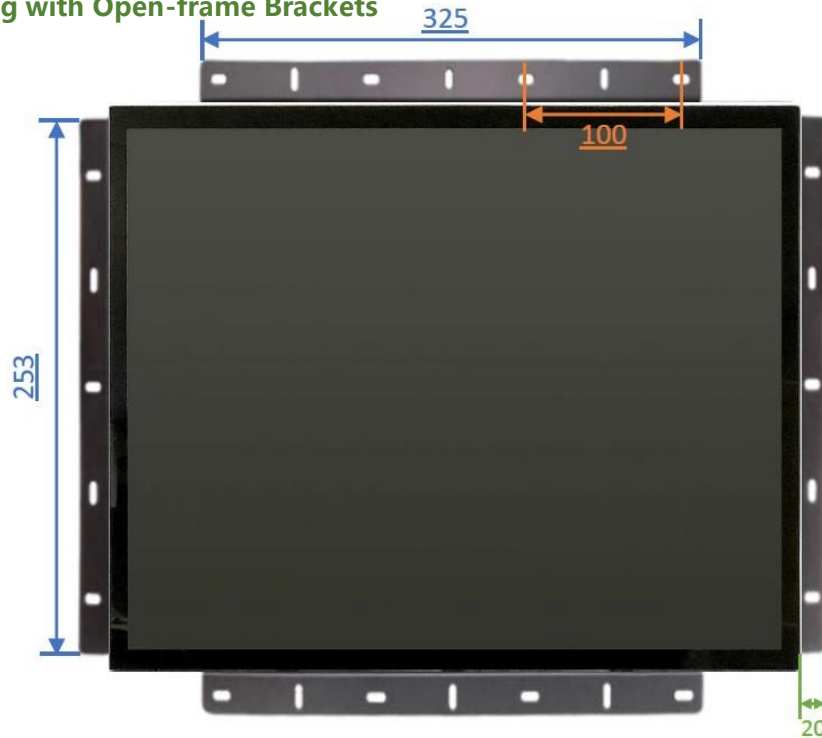

Panel Mount Kits (Option)

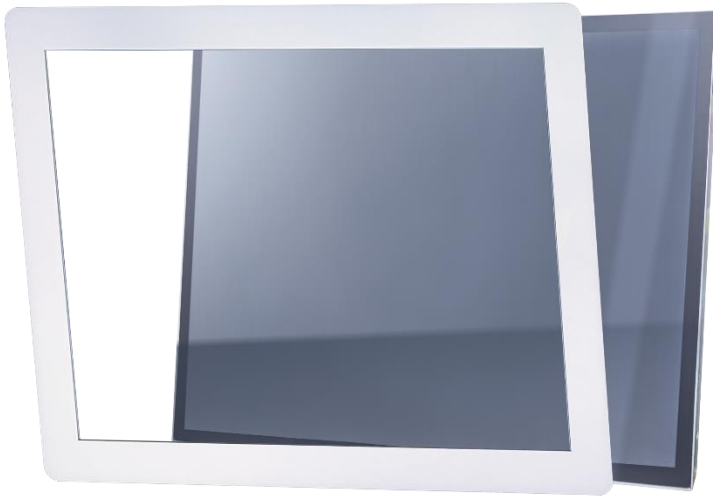

Dimension for Installing with Panel Mount Kit

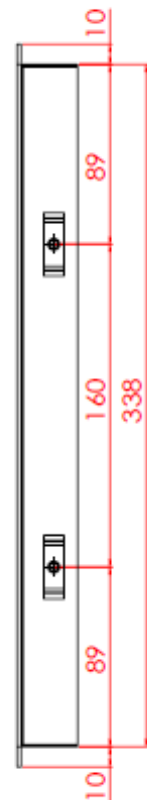
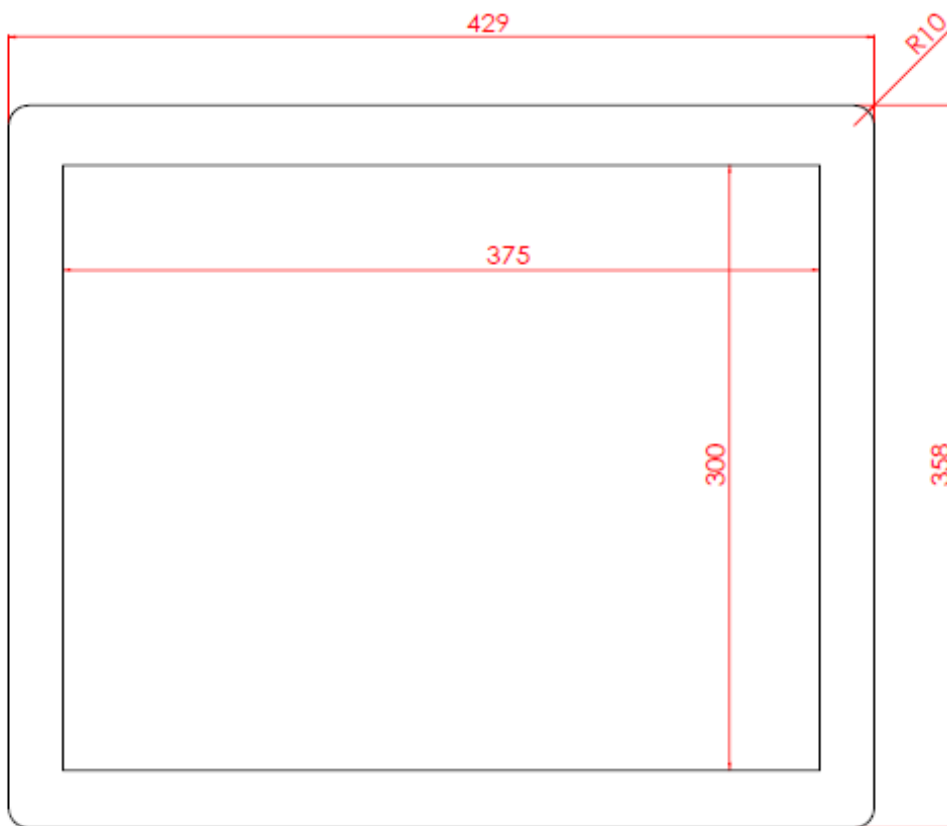
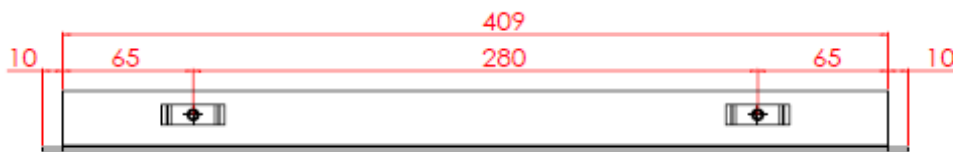

Nextech AP Series 19" Android All-in-one Industrial Touch PC

NTAP190-2 V500

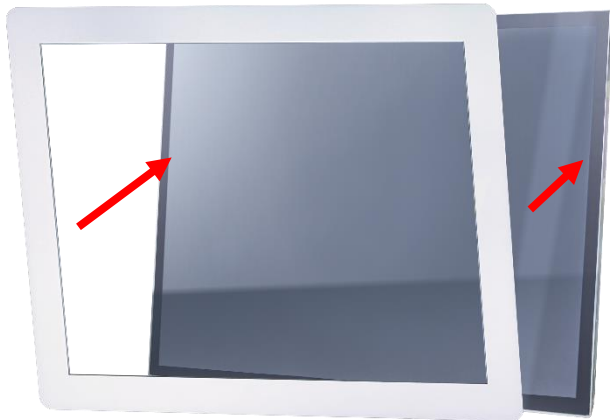

Step 1: Assemble the front module with the screen body. (This step is pre-assembled at the factory.)

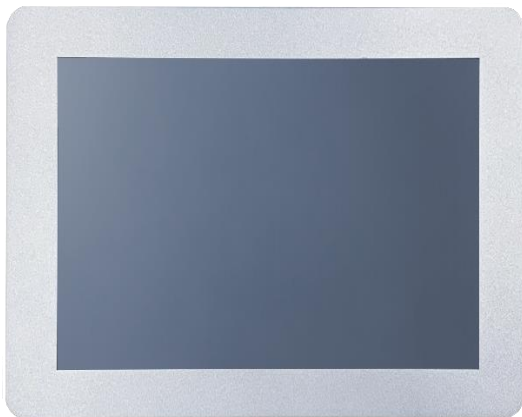
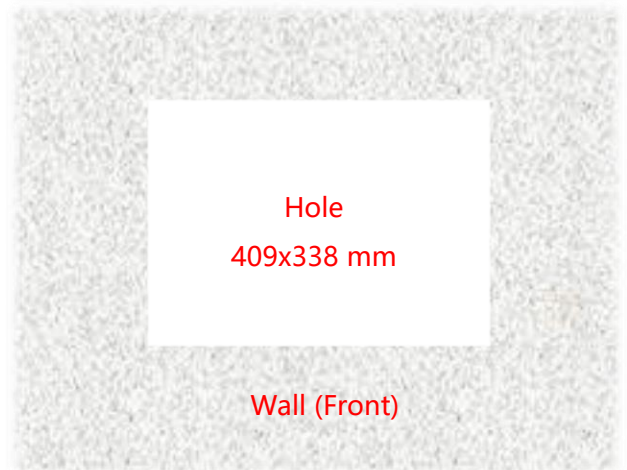

Step 2: Insert the screen from the front into the pre-cut opening.

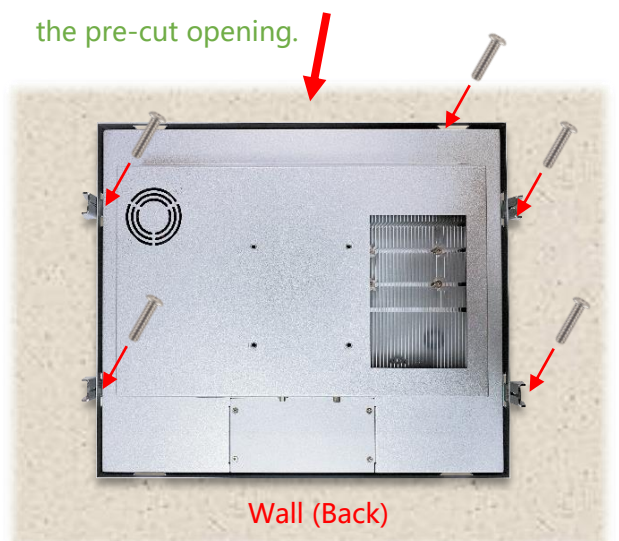

Step 3: Attach the clips from the back and secure with screws. (Up to 10 clips can be installed as needed or per positional limitations.)

Desktop Stand (Option)

Item	B Stand	Part No.	DST-0B002/DST-1B002
Mounting Pattern	100x100 / 75x75 mm	Dimension (WxHxD)	203x275x227 mm
Material	Steel/Plastic/Aluminum	Net Weight	1.8 KG
Tilt (Hinge)	-2° ~ +180°	Support Max. Weight	15 KG



Item	Z Stand	Part No.	DST-0BZ01/DST-1BZ01
Mounting Pattern	100x100 / 75x75 mm	Dimension (WxHxD)	190x240x41.6
Material	SECC	Net Weight	2.6 KG
Tilt (Hinge)	±360°	Support Max. Weight	15 KG

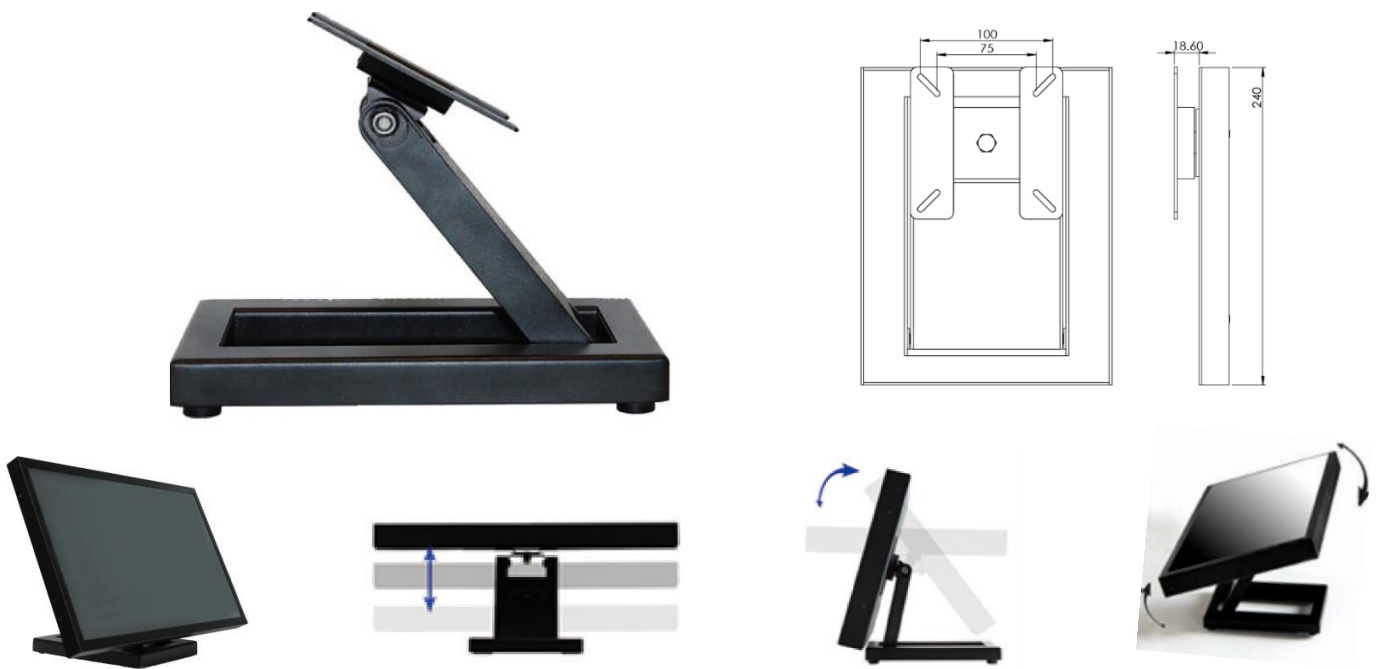

Wall Mount Bracket (Option)

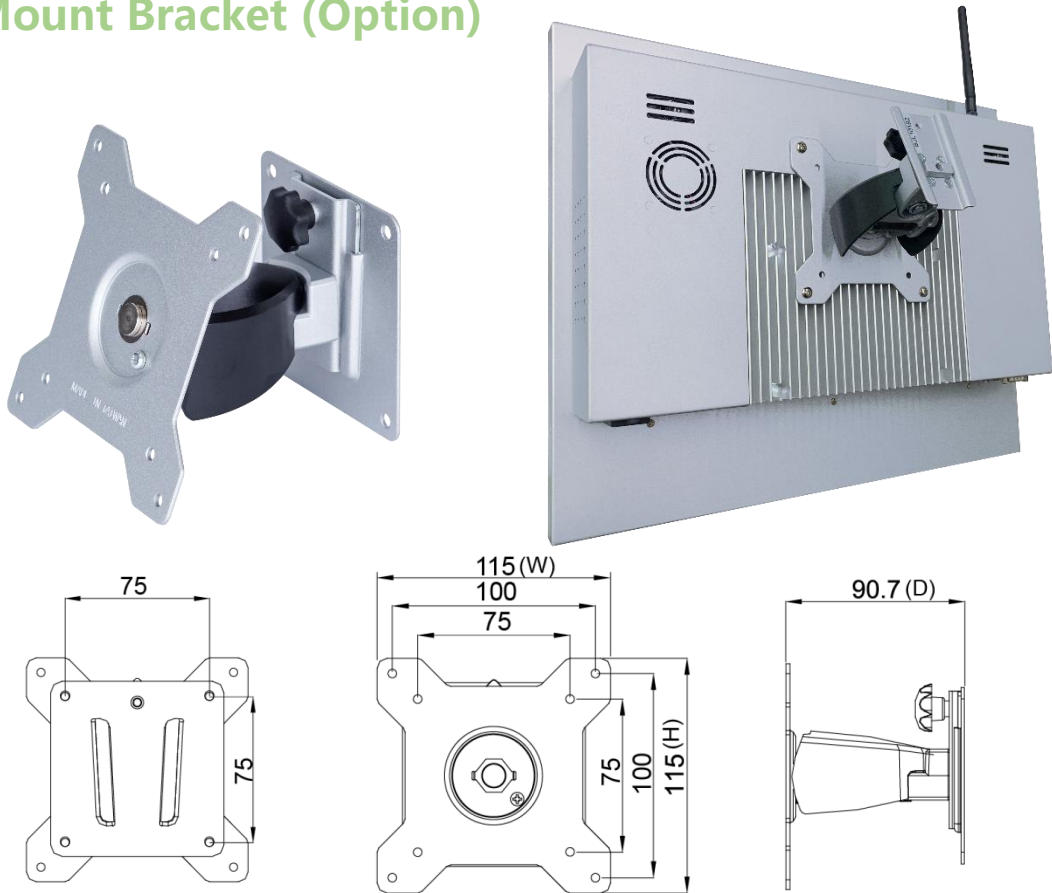

Packing Information

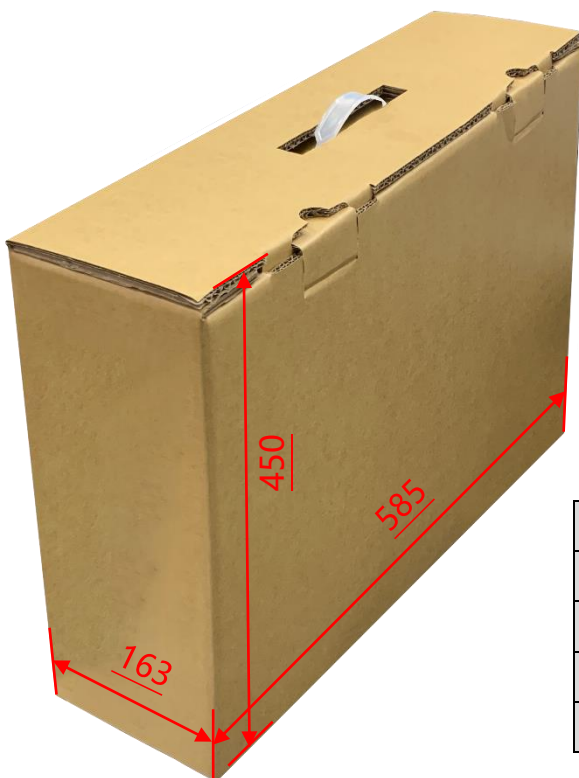

Unit Carton Size	585x163x450 mm
Unit N. Weight	≤4.5 KG
Unit G. Weight	≤5.1 KG
Units per Pallet	36 units
Pallet Size	120x100x147 CM

Physical Specifications

Dimension	399x328x47(±2)mm (W/O Antenna)	Net Weight	≤4.5 KG
VESA Mounting	100x100 mm	Gross Weight	≤5.1 KG

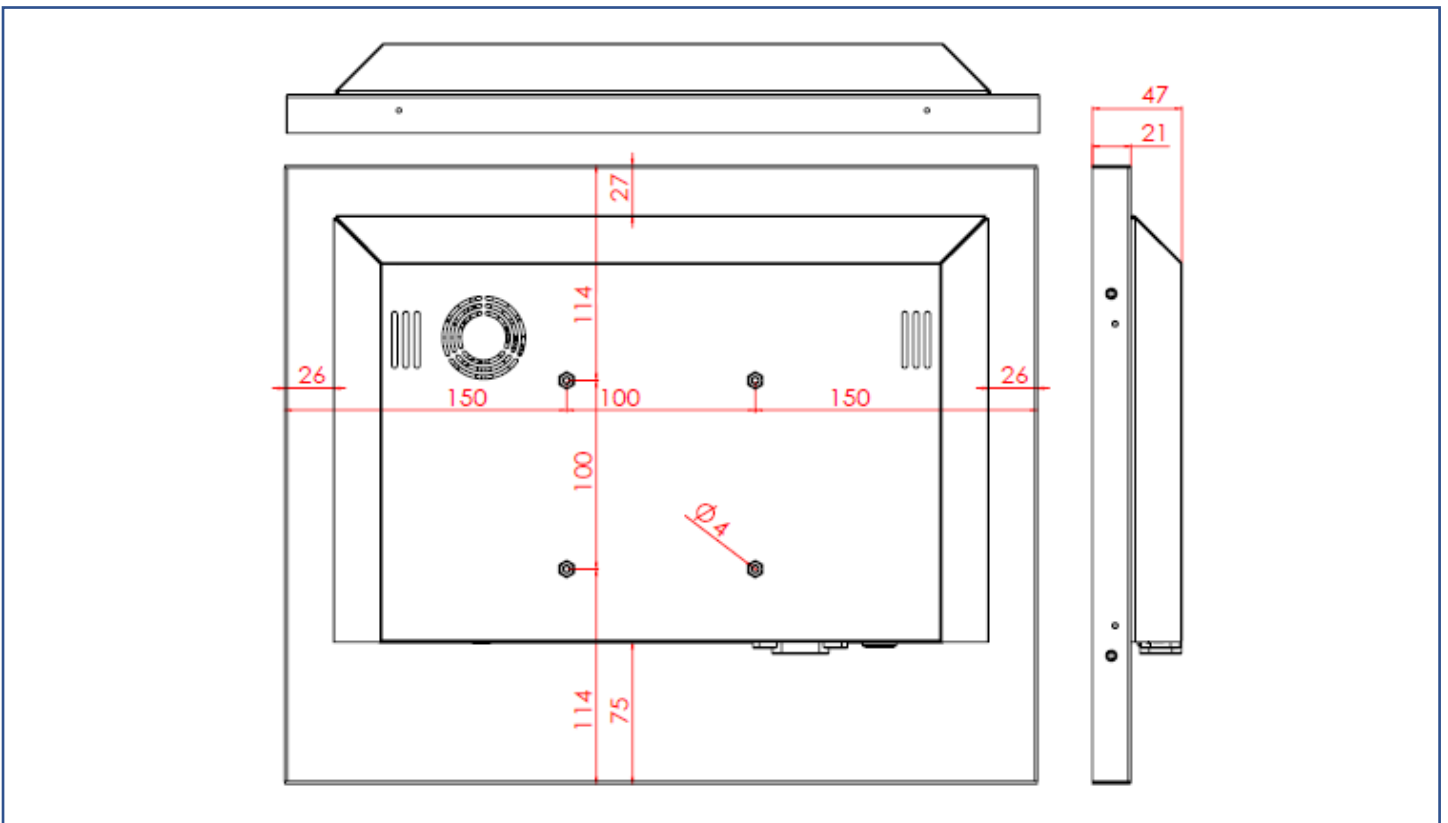
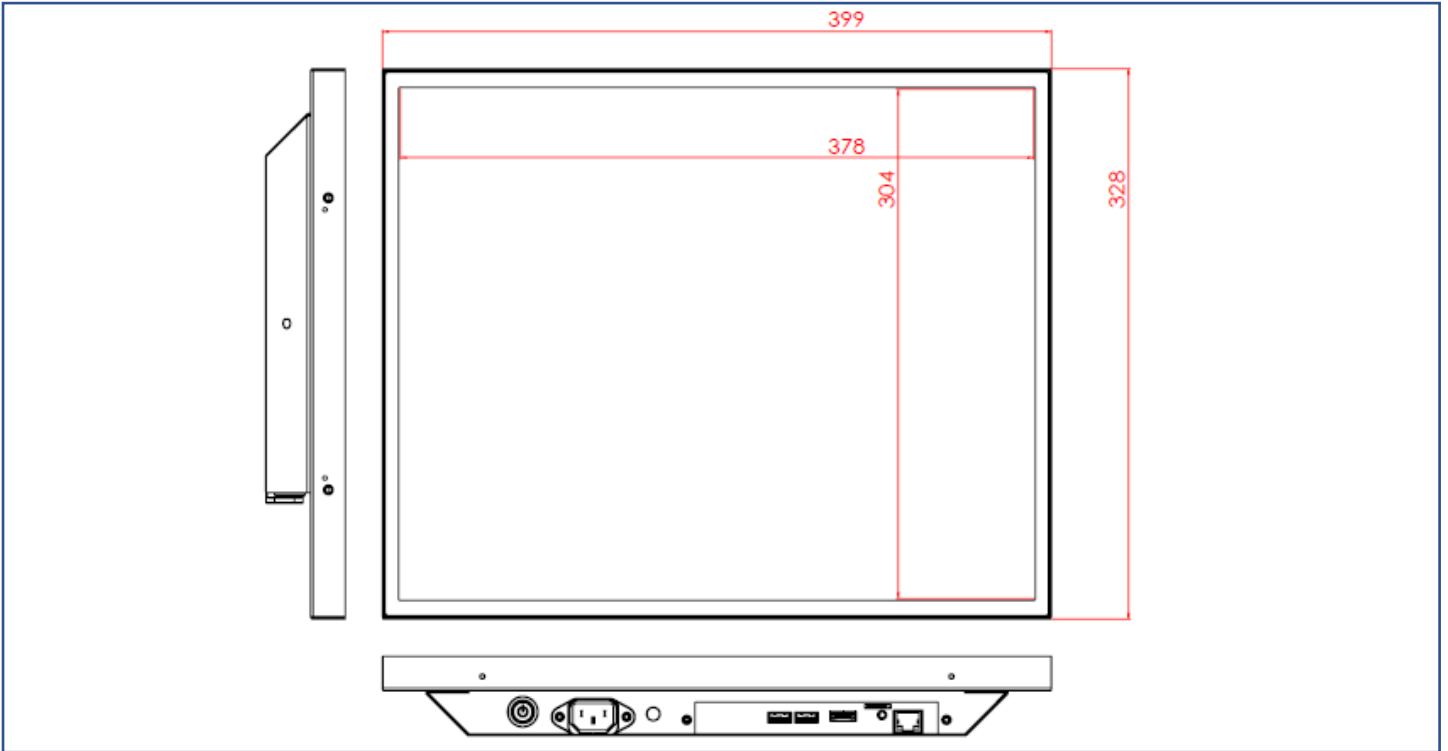

Cosmetic Inspection Standard

Display Area Allowance			
Defect description	Defective Specifications	Allowance	Remarks
Dot Defect (including dark dot, particles, bubbles, pits, dust, foreign matter)	$D \leq 0.2\text{mm}$	Ignored	D=Diameter
	$0.2 < D \leq 0.7\text{mm}$	$N \leq 5$	N=Quantity
	$0.7 < D \leq 1\text{mm}$	$N \leq 3$	
	$D > 1\text{mm}$	$N \leq 0$	
Linear Defect (including scratches, fluff, particles)	$W \leq 0.15\text{mm}$	Ignored	W=Width
	$0.15 < W \leq 0.5\text{mm}, L \leq 15\text{mm}$	$N \leq 2$	L=Length
	$W > 0.5\text{mm}$ or $L > 15\text{mm}$	NG	

* Visual inspection distance: 60cm, 90 degree (same for front/side/back)

Front Appearance Allowance (Including Coating)			
Defect description	Defective Specifications	Allowance	Remarks
Dot Defect (including particles, bubbles, pits...etc.)	$D \leq 0.7\text{mm}$	Ignored	D=Diameter
	$0.7 < D \leq 1.5\text{mm}$	$N \leq 3$	N=Quantity
	$D > 1.5\text{mm}$	$N \leq 0$	
Linear Defect (including scratches, fluff, particles)	$W \leq 0.2\text{mm}, L \leq 15\text{mm}$	Ignored	W=Width, L=Length
	$0.2 < W \leq 0.7\text{mm}, L \leq 15\text{mm}$	$N \leq 1$	
	$W > 0.7\text{mm}$ or $L > 15\text{mm}$	NG	

Side / Back Appearance Allowance (Including Coating)			
Defect description	Defective Specifications	Allowance	Remarks
Dot Defect (including particles, bubbles, pits...etc.)	$D \leq 1.5\text{mm}$	Ignored	D=Diameter
	$1.5 < D \leq 3\text{mm}$	$N \leq 8$	N=Quantity
	$D > 3\text{mm}$	$N \leq 2$	
Linear Defect (including scratches, fluff, particles)	$W \leq 0.8\text{mm}, L \leq 15\text{mm}$	Ignored	W=Width, L=Length
	$0.8 < W \leq 1.5\text{mm}, L \leq 15\text{mm}$	$N \leq 5$	
	$W > 1.5\text{mm}$ or $L > 15\text{mm}$	NG	

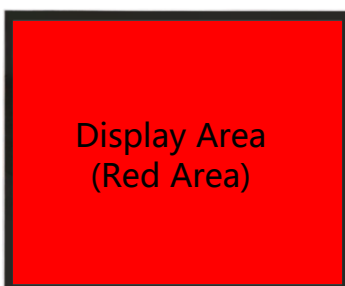

Display Area
(Red Area)



Front Appearance (Red Area)



Back Appearance