

Product Specifications

Customer	
Model	NTAP170-2-Q3 V500
Model No.	NTAP170<u>XX2XX</u>-Q3A84FA-<u>XXXX</u>-500

* X = A~Z, 0~9 (Depends on Options.)



Records of Revision			
Vision	Modifying	Old Description	New Description
v2110.1	Preliminary specification		
v2110.2	Carton modified		
v2110.3	Stylus pen option added		
v2110.4	New trademark released		
v2110.5	Hardware upgraded	DDR3 Memory Wi-Fi 5	DDR4 Memory Wi-Fi 6

Nextech P Series 17" Android All-in-one Industrial Touch PC

NTAP170-2-Q3 V500

Features

- ★ 17 inch Industrial Grade Panel, 1280x1024 Resolution
- ★ Operating Temperature Range -30~85°C
- ★ Rock Chip ARM Cortex A72+A53 RK3399 Quad-Core CPU
- ★ On Board DDR4 4G Memory
- ★ On Board 16G Flash ROM (Max. upgraded to 32G)
- ★ Micro SD Card Slot x1 (Max. to 64G)
- ★ Android 10.0
- ★ Narrow Bezel, True Flat Projected Capacitive Touch Screen
- ★ 7H Hardness Tempered Cover Glass
- ★ 10 points Multi-touch, Supports NEXTECH Dedicated Stylus
- ★ Metal Cabinet with Diverse Combine Options
- ★ Made in Taiwan, 3 Years Warranty, Designed for Harsh Environments
- ★ Optional High Brightness 1500nits, for Outdoor Environment
- ★ Optional AG Coating/Antibacterial/Privacy Filter Surface Treatment



PSE



BSMI



CE



ISO9001



FCC

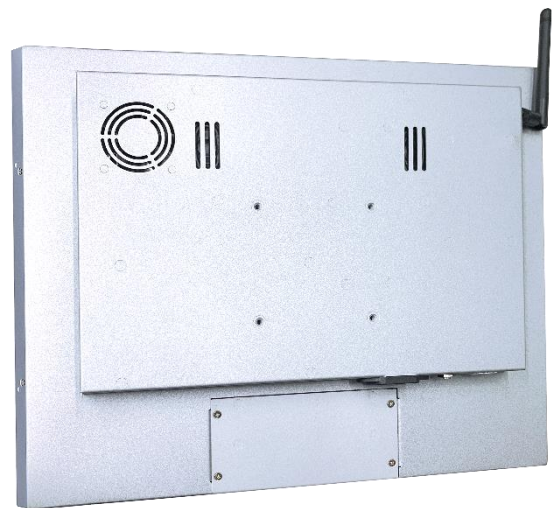

Desktop Stand



Wall Mounting



Open-frame Bracket



Panel Mount

System Specifications

CPU	Dual Core ARM Cortex-A72 +Cortex-A53 up to 2.0GHz
Memory	Samsung LPDDR4 4G
Storage	Samsung 16G EMMC Flash ROM (Max. to 32G)
GPU Chip	Mali-T860 GPU
Sound Chip	Realtek ALC662 Audio CODEC
Physical Network	1x GbE Lan port (RJ45)
Wireless Network	Wi-Fi 6 and Blue Tooth v2.1+EDR/V3.0/V3.0+HS/V4.0
OS	Android 10.0

Display Specifications

Screen Diagonal	432mm (17.0 inch)	Display Mode	TN Type, Normally Black
Display Area	337.9x270.3 mm	Backlight Unit	LED (white LED)
Resolution	1280x1024	Viewing Angle (L/R, U/D)	80°/80°/60°/80°
Contrast Ratio	800:1	Response Time	30 msec.
Display Ratio	4:3	Backlight Lifetime	>50,000 Hours
Support Colors	16.7M Colors	Operating Temp.	-30~85°C
Pixel Pitch	264x264 um	Storage Temp.	-30~85°C

Display Options

Brightness			
	Brightness	Environment	Model Name
Standard	350nits	General	NTAP170N <u>X2XX</u> -Q3A84FA- <u>XXXX</u> -500
Option 1	1000nits	Outdoor Environment	NTAP170A <u>X2XX</u> -Q3A84FA- <u>XXFX</u> -500
Option 2	1500nits	Sunlight Readable	NTAP170F <u>X2XX</u> -Q3A84FA- <u>XXFX</u> -500

Nextech P Series 17" Android All-in-one Industrial Touch PC

NTAP170-2-Q3 V500

Touch Options

Projected Capacitive			
Model Name	NTAP170X <u>P2XX</u> -Q3A84FA-XXXX-500		
Touch Technology	Projected Capacitive	Thickness of Cover Lens	2.0±0.2mm
Allowed Touch Points	10 points	Hardness of Cover Lens	7H
Transparency	≥87%	IK Ratings	IK07
Accuracy	99.00%		

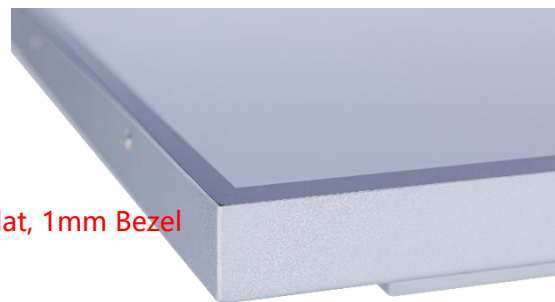

* True Flat, 1mm Bezel

Non-Touch	
Model Name	NTAP170X <u>02XX</u> -Q3A84FA-XXXX-500

Surface Treatment		
	Description	Model Name
Standard	(none)	NTAP170XX2<u>00</u>-Q3A84FA-XXXX-500
Option 1	Anti-Glare Coating	NTAP170XX2 <u>GG</u> -Q3A84FA-XXXX-500
Option 2	Antibacterial (AB Film)	NTAP170XX2 <u>AB</u> -Q3A84FA-XXXX-500
Option 3	Anti-Spy (AS Film)	NTAP170XX2 <u>SF</u> -Q3A84FA-XXXX-500

Passive Stylus Pen (Option)	
Technology	Passive High Sensitive Knitted Wire Mesh Fiber Tip
Size of tip	6mm
Magnetic Attachment	Yes

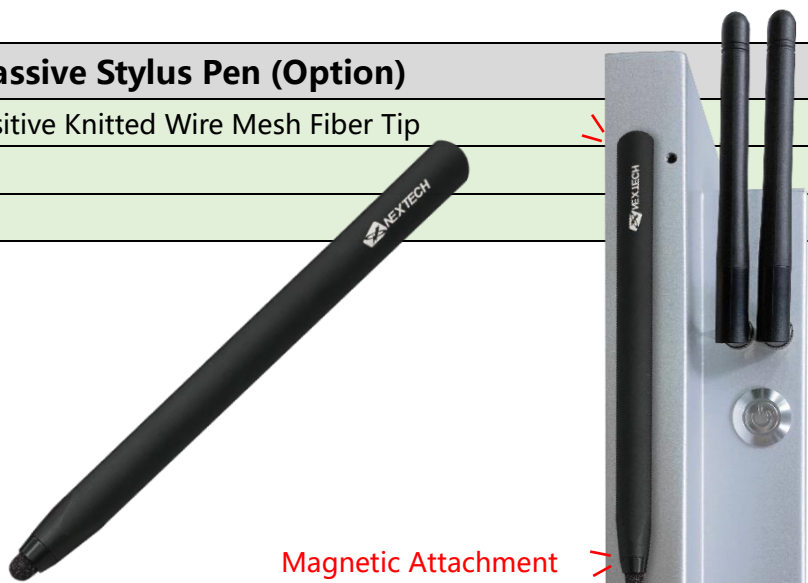

Magnetic Attachment

System Options

Material of Cabinet		
	Description	Model Name
Standard	SECC	NTAP170XX2XX-Q3A84FA-SXXX-500
Option 1	Stainless Steel	NTAP170XX2XX-Q3A84FA-LXXX-500
Option 2	Aluminum	NTAP170XX2XX-Q3A84FA-AXXX-500

Color of Cabinet		
	Description	Model Name
Standard	Silver	NTAP170XX2XX-Q3A84FA-XSXX-500
Option 1	White	NTAP170XX2XX-Q3A84FA-XWXX-500
Option 2	Black	NTAP170XX2XX-Q3A84FA-XBXX-500
Options	Other Colors	NTAP170XX2XX-Q3A84FA-XXXX-500

* X = A~Z, 0~9 (Depends on Color)

Cooling Fan		
	Description	Model Name
Standard	Fanless	NTAP170XX2XX-Q3A84FA-XX0X-500
Option	7 Blades/4000r.p.m/28.3dB	NTAP170XX2XX-Q3A84FA-XXFX-500

Power Input		
	Description	Model Name
Standard	12VDC-in, with AC/DC Adapter	NTAP170XX2XX-Q3A84FA-XXX2-500
Option	100~240V AC, C14 AC Power Socket	NTAP170XX2XX-Q3A84FA-XXXA-500



DC-in



AC-in

Input /Output System

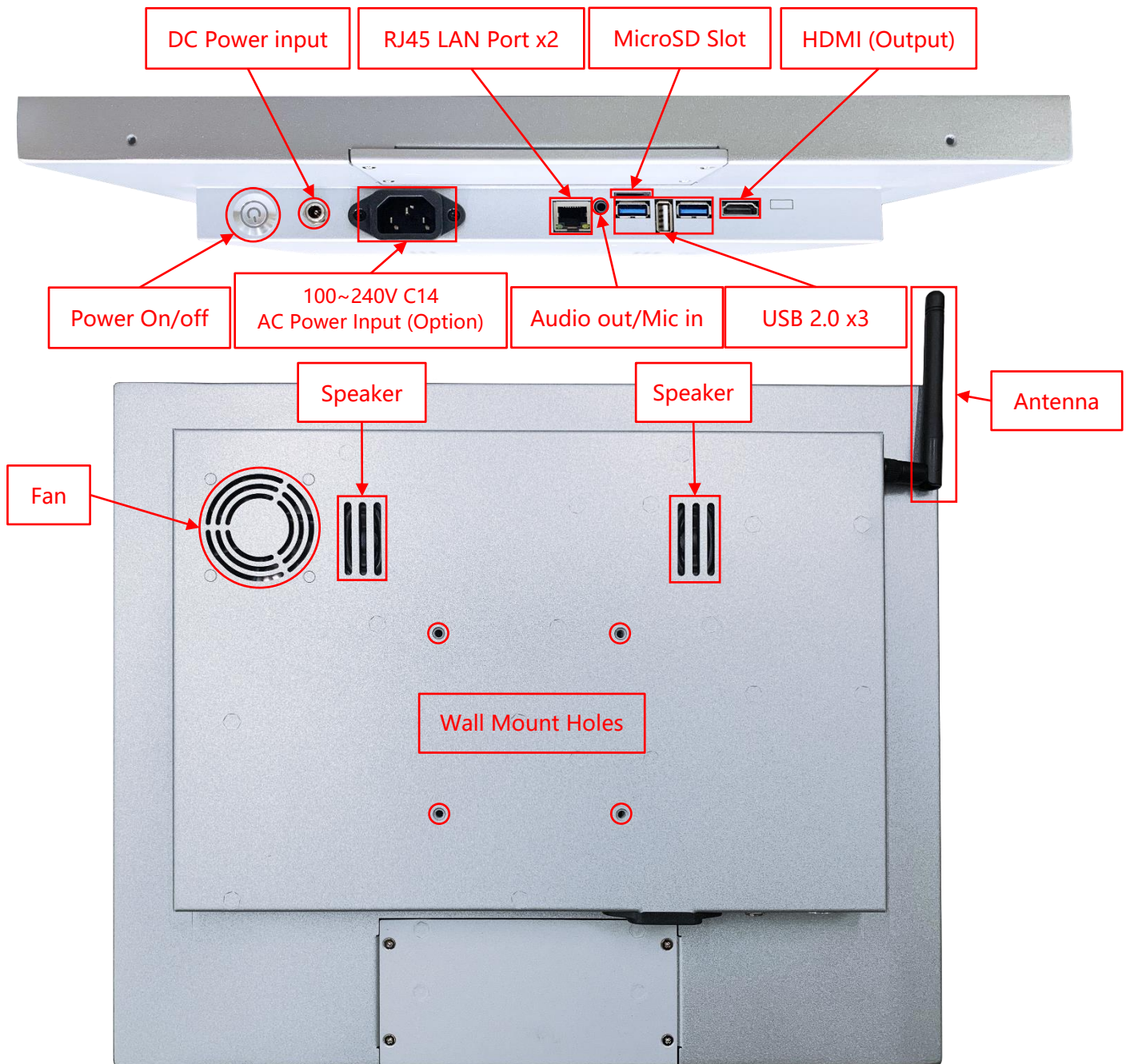

Input / Output	Connectors	Input / Output	Connectors
HDMI (Output)	1	USB 2.0	3
Audio Output /Mic Input (3.5mm)	1	MicroSD Card Slot	1
DC Power Input	1	LAN (RJ45)	1
AC Power Input	Option	Wi-Fi/Bluetooth & Antenna	1
Speakers	2W x2		

Front Cover (Option)

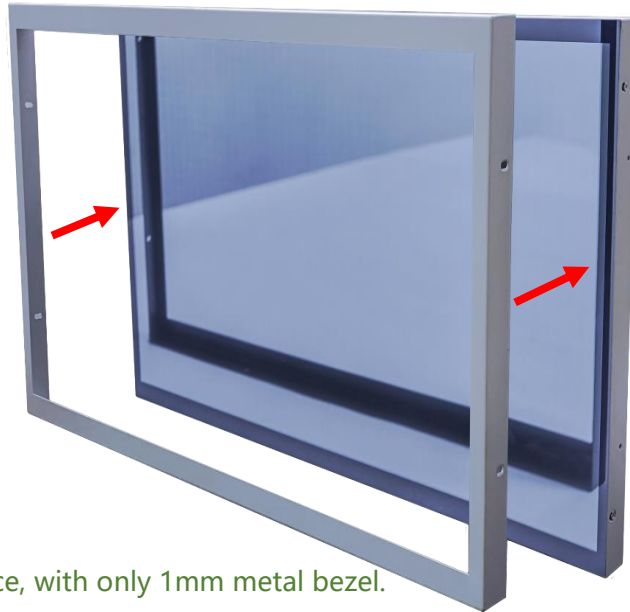

The standard **NTAP170** is true flat surface, with only 1mm metal bezel.
To protect the corners of the touch screen, the **Front Cover** can be added.



The watertight gasket can be added between the **Front Cover** and **NTAP170**.
It complies **IP65** on front.

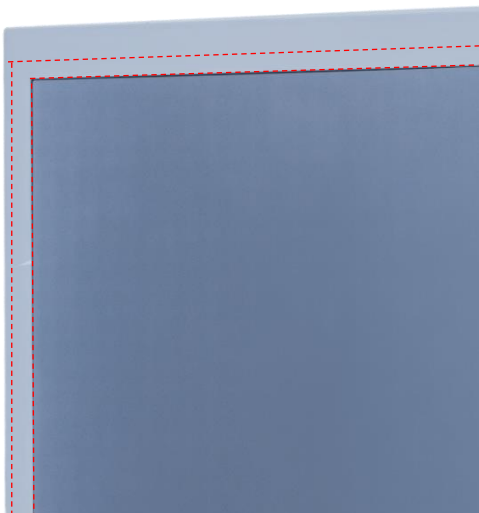

Open-frame Brackets (Option)

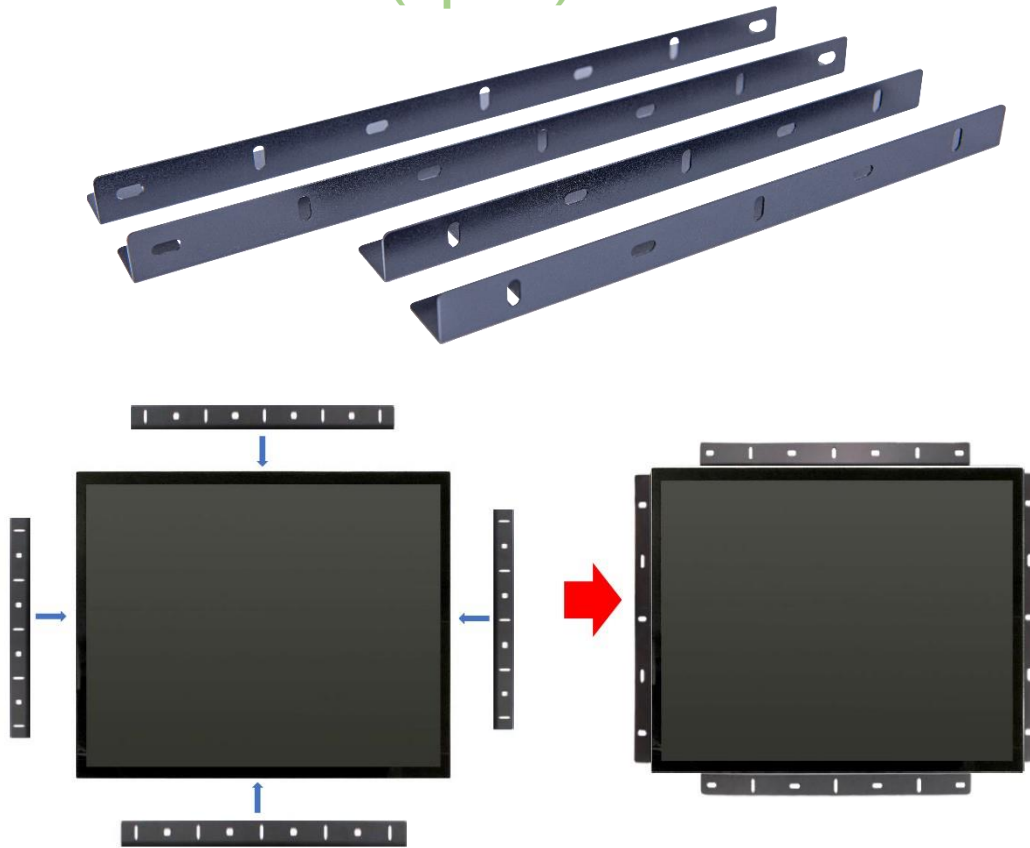

Dimension for Installing with Open-frame Brackets

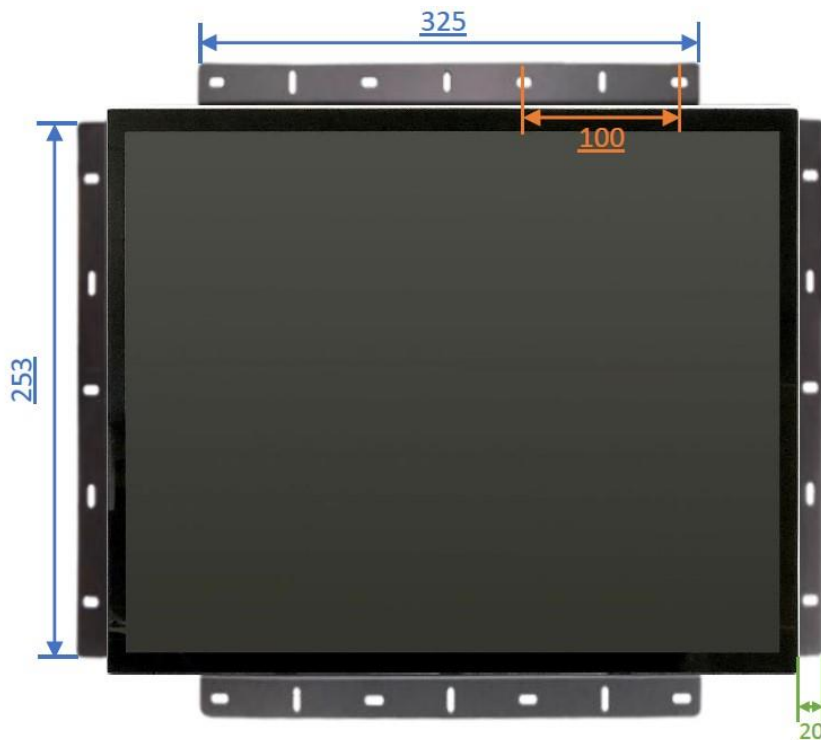

Panel Mount Kits (Option)



Dimension for Installing with Panel Mount Kit

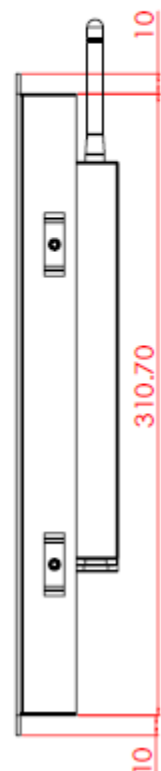
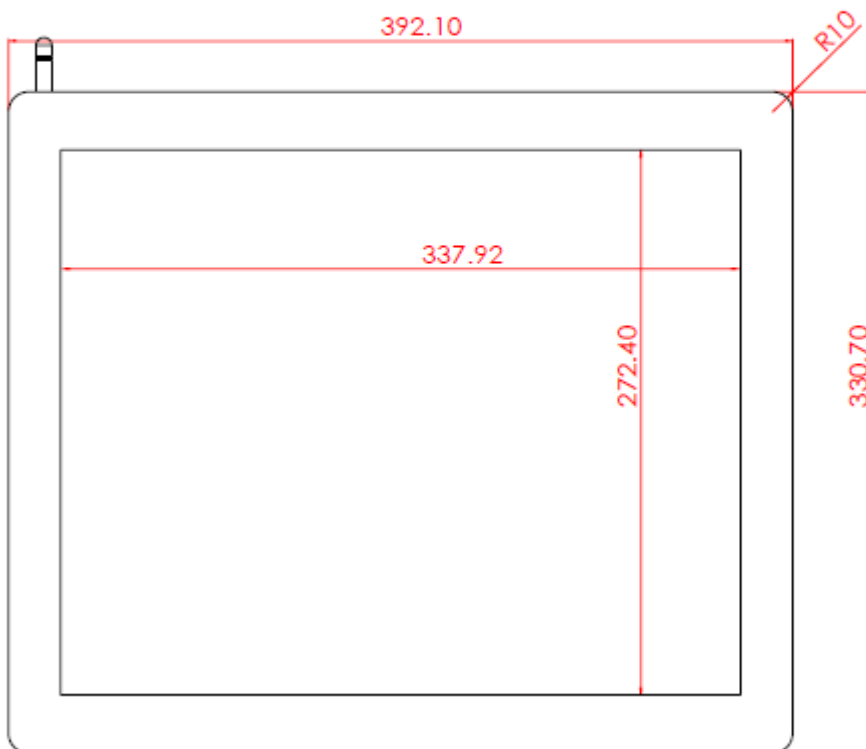
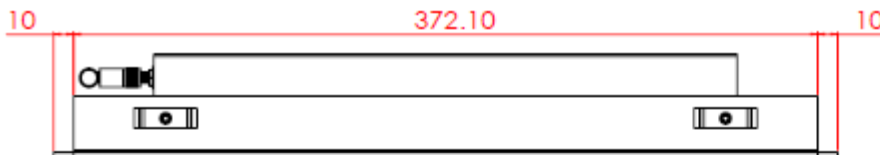

Nextech P Series 17" Android All-in-one Industrial Touch PC

NTAP170-2-Q3 V500

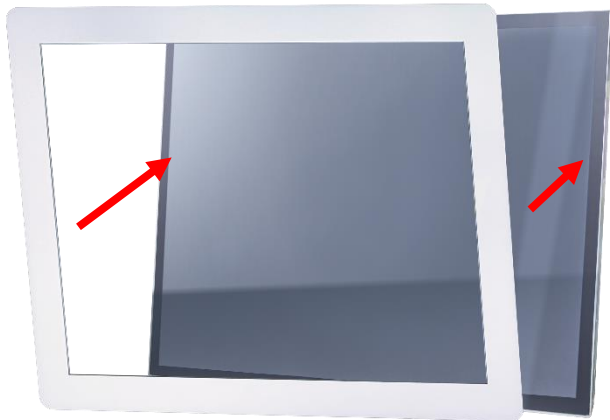

Step 1: Assemble the front module with the screen body. (This step is pre-assembled at the factory.)

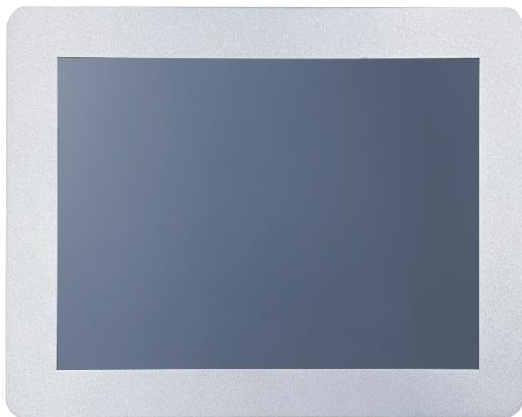
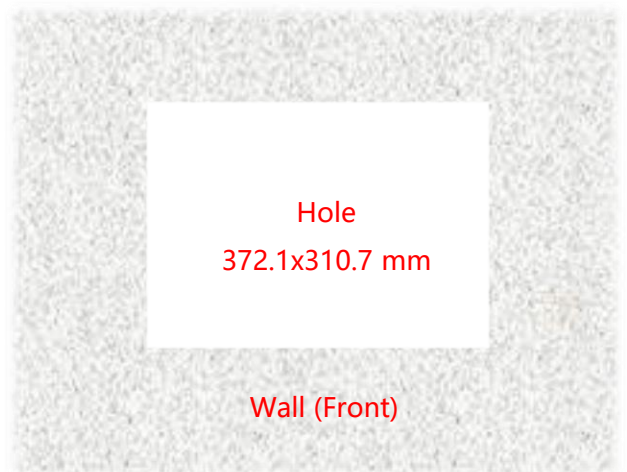

Step 2: Insert the screen from the front into the pre-cut opening.

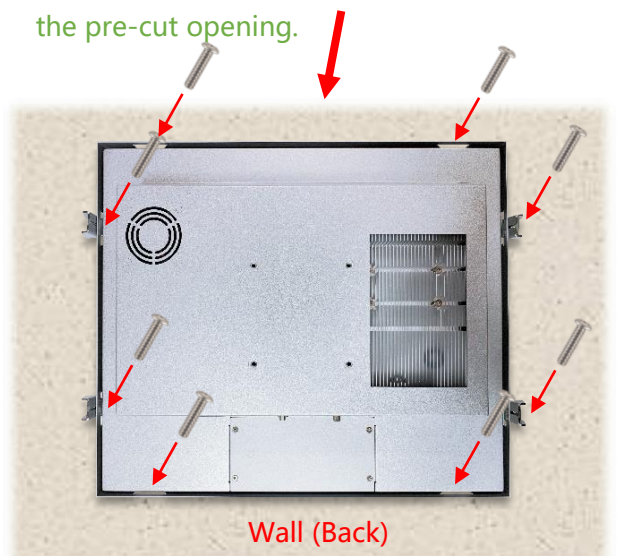

Step 3: Attach the clips from the back and secure with screws. (Up to 8 clips can be installed as needed or per positional limitations.)

Nextech P Series 17" Android All-in-one Industrial Touch PC

NTAP170-2-Q3 V500

Desktop Stand (Option)

Item	B Stand	Part No.	DST-0B002/DST-1B002
Mounting Pattern	100x100 / 75x75 mm	Dimension (WxHxD)	203x275x227 mm
Material	Steel/Plastic/Aluminum	Net Weight	1.8 KG
Tilt (Hinge)	-2° ~ +180°	Support Max. Weight	15 KG



Item	Z Stand	Part No.	DST-0BZ01/DST-1BZ01
Mounting Pattern	100x100 / 75x75 mm	Dimension (WxHxD)	190x240x41.6
Material	SECC	Net Weight	2.6 KG
Tilt (Hinge)	±360°	Support Max. Weight	15 KG



Nextech P Series 17" Android All-in-one Industrial Touch PC

NTAP170-2-Q3 V500

Wall Mount Bracket (Option)

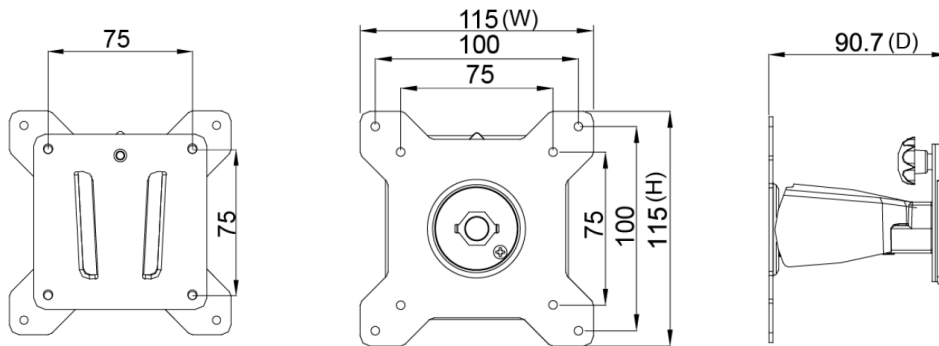

Packing Information

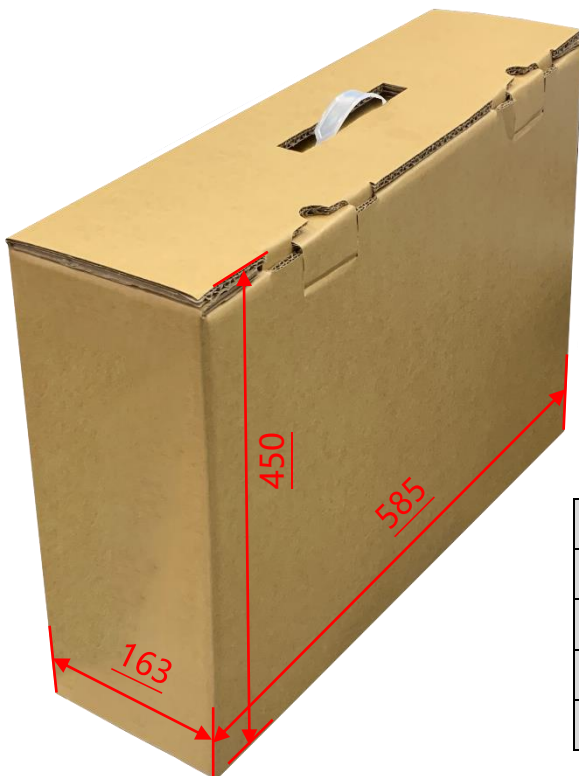

Unit Carton Size	585x163x450 mm
Unit N. Weight	≤3.9 KG
Unit G. Weight	≤4.5 KG
Units per Pallet	36 units
Pallet Size	120x100x147 CM

Physical Specifications

Dimension	301x362x48(±2)mm (W/O Antenna)	Net Weight	≤3.9 KG
VESA Mounting	75x75 mm	Gross Weight	≤4.5 KG

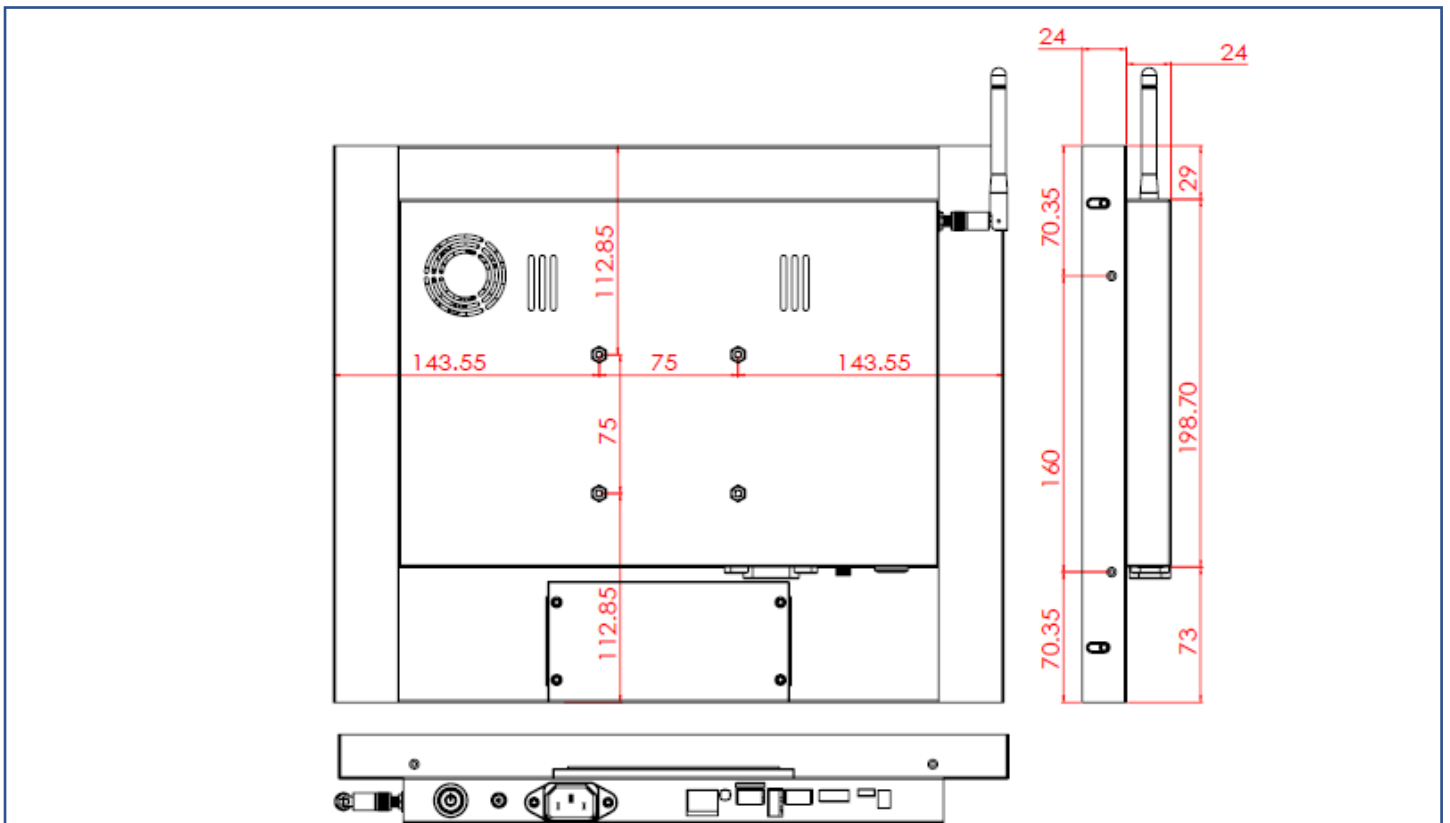
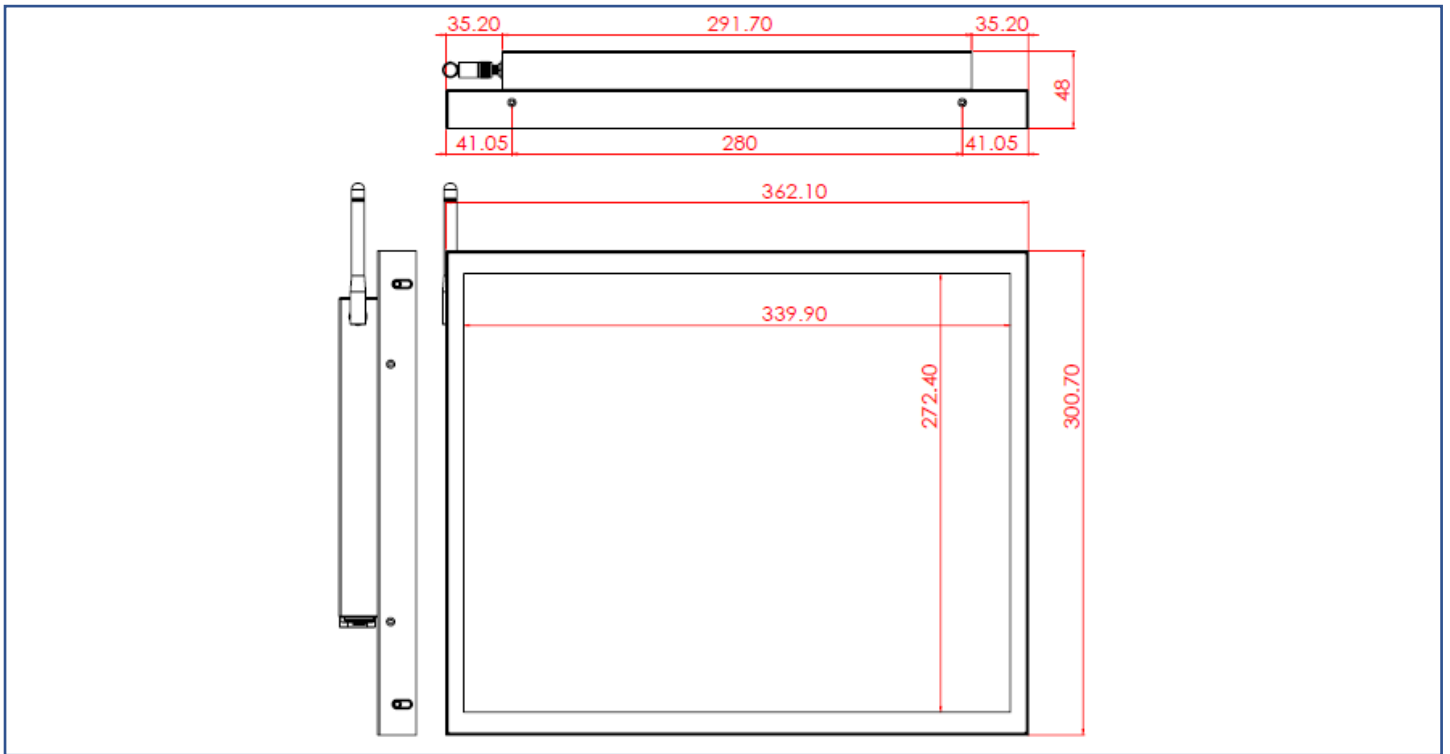

Cosmetic Inspection Standard

Display Area Allowance			
Defect description	Defective Specifications	Allowance	Remarks
Dot Defect (including dark dot, particles, bubbles, pits, dust, foreign matter)	$D \leq 0.2\text{mm}$	Ignored	D=Diameter
	$0.2 < D \leq 0.7\text{mm}$	$N \leq 5$	N=Quantity
	$0.7 < D \leq 1\text{mm}$	$N \leq 3$	
	$D > 1\text{mm}$	$N \leq 0$	
Linear Defect (including scratches, fluff, particles)	$W \leq 0.15\text{mm}$	Ignored	W=Width
	$0.15 < W \leq 0.5\text{mm}, L \leq 15\text{mm}$	$N \leq 2$	L=Length
	$W > 0.5\text{mm}$ or $L > 15\text{mm}$	NG	

* Visual inspection distance: 60cm, 90 degree (same for front/side/back)

Front Appearance Allowance (Including Coating)			
Defect description	Defective Specifications	Allowance	Remarks
Dot Defect (including particles, bubbles, pits...etc.)	$D \leq 0.7\text{mm}$	Ignored	D=Diameter
	$0.7 < D \leq 1.5\text{mm}$	$N \leq 3$	N=Quantity
	$D > 1.5\text{mm}$	$N \leq 0$	
Linear Defect (including scratches, fluff, particles)	$W \leq 0.2\text{mm}, L \leq 15\text{mm}$	Ignored	W=Width, L=Length
	$0.2 < W \leq 0.7\text{mm}, L \leq 15\text{mm}$	$N \leq 1$	
	$W > 0.7\text{mm}$ or $L > 15\text{mm}$	NG	

Side / Back Appearance Allowance (Including Coating)			
Defect description	Defective Specifications	Allowance	Remarks
Dot Defect (including particles, bubbles, pits...etc.)	$D \leq 1.5\text{mm}$	Ignored	D=Diameter
	$1.5 < D \leq 3\text{mm}$	$N \leq 8$	N=Quantity
	$D > 3\text{mm}$	$N \leq 2$	
Linear Defect (including scratches, fluff, particles)	$W \leq 0.8\text{mm}, L \leq 15\text{mm}$	Ignored	W=Width, L=Length
	$0.8 < W \leq 1.5\text{mm}, L \leq 15\text{mm}$	$N \leq 5$	
	$W > 1.5\text{mm}$ or $L > 15\text{mm}$	NG	



Display Area
(Red Area)



Front Appearance (Red Area)



Back Appearance