

Product Specifications

Customer	
Model	NTAP101-Q2 V500
Model No.	NTAP101N<u>X</u>S<u>XX</u>-Q2A72F8-<u>XX</u>02-500

* X = A~Z, 0~9 (Depends on Options.)



Records of Revision			
Vision	Modifying	Old Description	New Description
v2107.1	Preliminary Specification		
v2107.2	Add the Panel Mount Kits		

Features

- ★ 10.1 inch Wide Screen Industrial Grade Panel, 1280x800 Resolution
- ★ AHVA Wide Viewing Angle Technology , 178°/178°
- ★ Wide Operating Temperature Range -20~60°C
- ★ Rock Chip ARM Cortex A17 RK3288 Quad-Core 1.8GHz CPU
- ★ On Board DDR3 2G RAM
- ★ On Board 8G Flash ROM (Max. upgraded to 32G)
- ★ Micro SD Card Slot x1 (Max. to 64G)
- ★ Android 10.0
- ★ Narrow Bezel, True Flat Projected Capacitive Touch Screen
- ★ 7H Hardness Tempered Cover Glass
- ★ 10 points Multi-touch, Supports Active Stylus
- ★ Metal Cabinet with Diverse Combine Options
- ★ Made in Taiwan, 3 Years Warranty, Designed for Harsh Environments
- ★ Optional AG Coating/Antibacterial/Privacy Filter Surface Treatment



PSE



BSMI



RoHS



CE



ISO9001



FCC

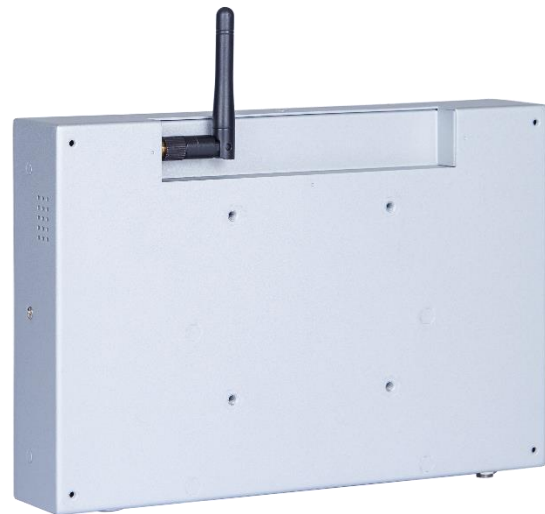

Desktop Stand



Wall Mounting



Open-frame Bracket



Panel Mount



System Specifications

CPU	Rock Chip ARM Cortex A17 RK3288 Quad-Core 1.8GHz
Memory	DDR3 2G
Storage	8G Flash ROM (Max. to 32G)
GPU Chip	Mali T764 GPU
Sound Chip	ES8316 2 Channel HD Audio
Physical Network	1x GbE Lan port (RJ45)
Wireless Network	IEEE 802.11b/g/n 2.4G WIFI and Blue Tooth v2.1+EDR/V3.0/V3.0+HS/V4.0
OS	Android 10.0
Power Input	12VDC-in, with AC/DC Adapter

Display Specifications

Screen Diagonal	10.1 inch	Display Mode	AHVA Type, Normally Black
Display Area	216.96x135.6 mm	Backlight Unit	LED (white LED)
Resolution	1280x800	Response Time	29 msec. (Typ.)
Contrast Ratio	800:1	Viewing Angle (L/R, U/D)	178°/178°
Display Ratio	16:10	Backlight Lifetime	>30,000 Hours
Support Colors	16.7M Colors	Operating Temp.	-20~60°C
Pixel Pitch	0.1695x0.1695 mm	Storage Temp.	-20~60°C
Brightness	400nits	Surface Treatment	Hard Coating

Packing Information



Dimensions of Carton	390x320x90 mm
Net Weight	≤1.4 KG
Gross Weight	≤2.5 KG

Touch Options

Projected Capacitive			
Model Name	NTAP101N <u>P</u> SXX-Q2A72F8- <u>XX</u> 02-500		
Touch Technology	Projected Capacitive	Thickness of Cover Lens	1.1±0.2mm
Allowed Touch Points	10 points	Hardness of Cover Lens	7H
Transparency	≥87%	IK Ratings	IK07
Accuracy	99.00%		



* True Flat, 1mm Bezel

Non-Touch	
Model Name	NTAP101N <u>0</u> SXX-Q2A72F8- <u>XX</u> 02-500

Surface Film Options		
	Description	Model Name
Standard	(none)	NTAP101NXS<u>00</u>-Q2A72F8-<u>XX</u>02-500
Option 1	Anti-Glare Coating	NTAP101NXS <u>GG</u> -Q2A72F8- <u>XX</u> 02-500
Option 2	Antibacterial (AB Film)	NTAP101NXS <u>AB</u> -Q2A72F8- <u>XX</u> 02-500
Option 3	Anti-Spy (AS Film)	NTAP101NXS <u>SF</u> -Q2A72F8- <u>XX</u> 02-500



System Options

Material of Cabinet		
	Description	Model Name
Standard	SECC	NTAP101N<u>X</u>S<u>X</u>X-Q2A72F8-<u>S</u>X02-500
Option 1	Stainless Steel	NTAP101N <u>X</u> S <u>X</u> X-Q2A72F8- <u>L</u> X02-500
Option 2	Aluminum	NTAP101N <u>X</u> S <u>X</u> X-Q2A72F8- <u>A</u> X02-500

Color of Cabinet		
	Description	Model Name
Standard	Silver	NTAP101N<u>X</u>S<u>X</u>X-Q2A72F8-<u>X</u>S02-500
Option 1	White	NTAP101N <u>X</u> S <u>X</u> X-Q2A72F8- <u>X</u> W02-500
Option 2	Black	NTAP101N <u>X</u> S <u>X</u> X-Q2A72F8- <u>X</u> B02-500
Options	Other Color	NTAP101N <u>X</u> S <u>X</u> X-Q2A72F8- <u>X</u> X02-500

* X = A~Z, 0~9 (Depends on Color)

Input /Output System

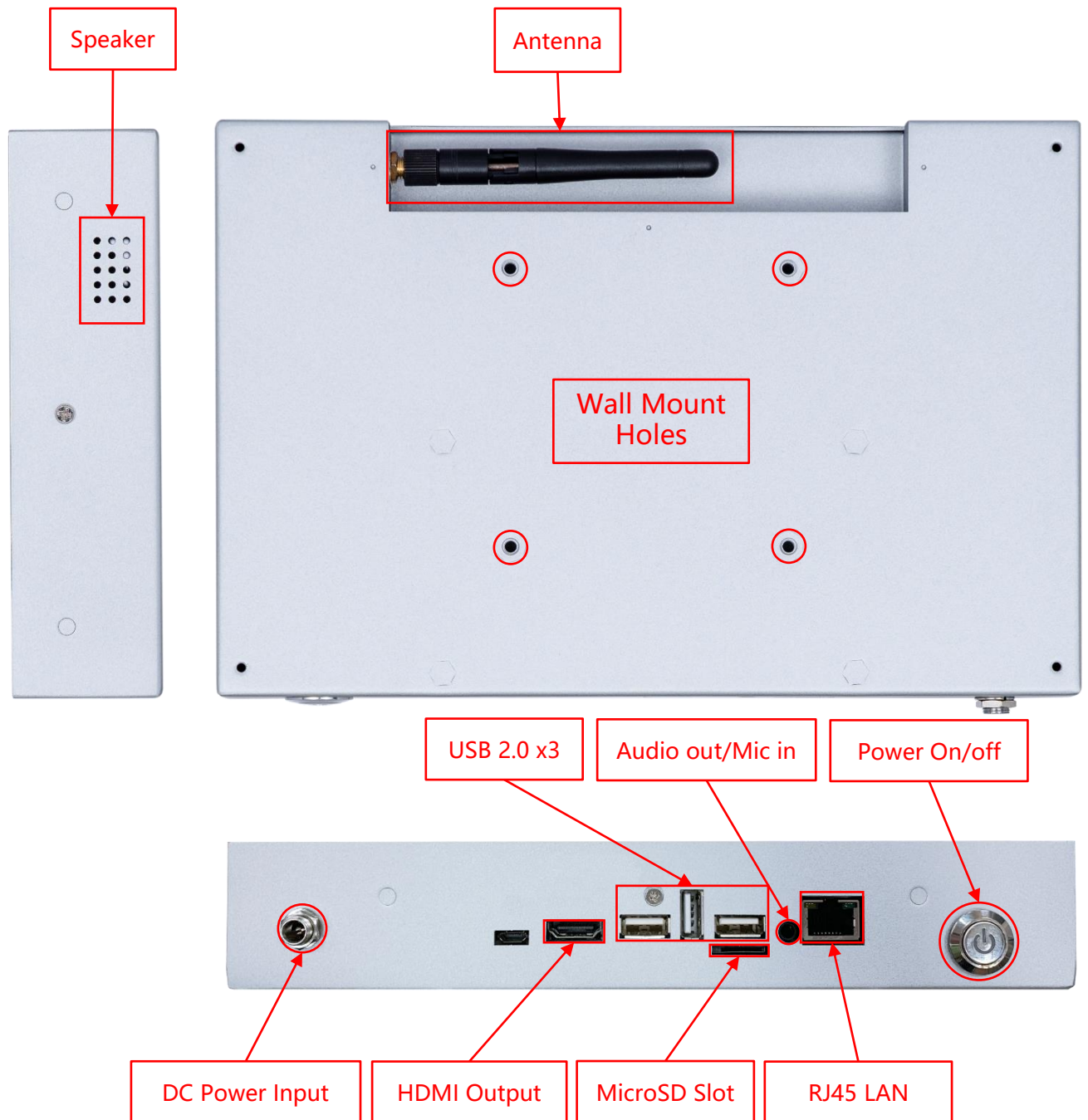

Input / Output	Connectors	Input / Output	Connectors
HDMI (Output)	1	USB 2.0	3
Audio Output /Mic Input (3.5mm)	1	MicroSD Card Slot	1
DC Power Input	1	LAN (RJ45)	1
Speakers	1W x2	Wi-Fi & Antenna	1

Front Cover (Option)

The standard **NTAP101** is true flat surface, with only 1mm metal bezel
To protect the corners of the touch screen, the **Front Cover** can be added.

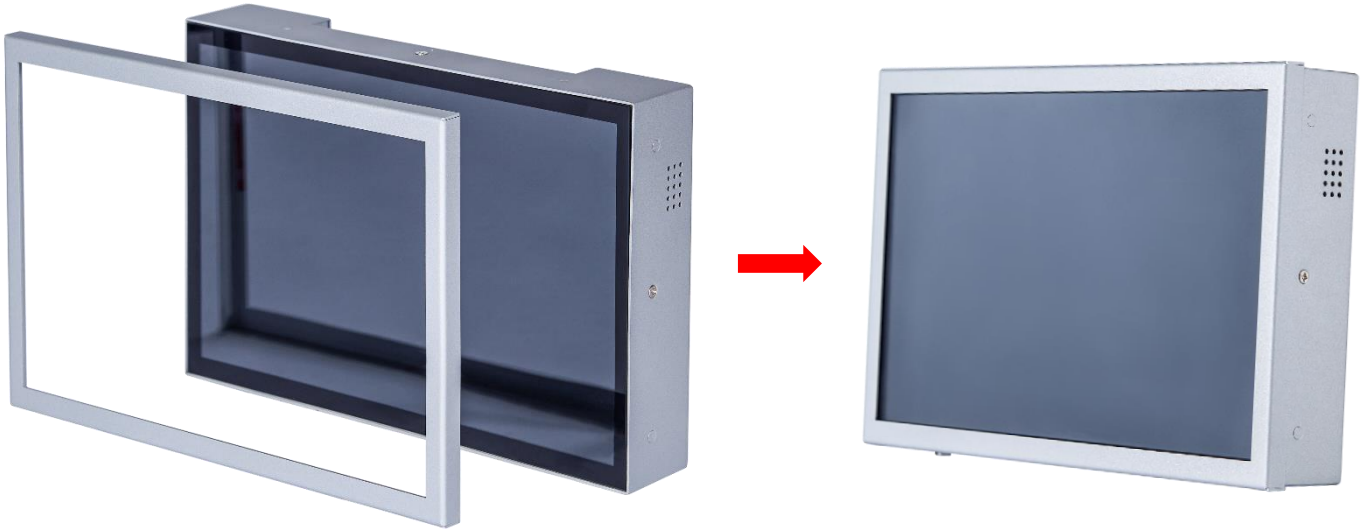

The watertight gasket can be added between the **Front Cover** and **NTAP101**.
It complies **IP65** on front.

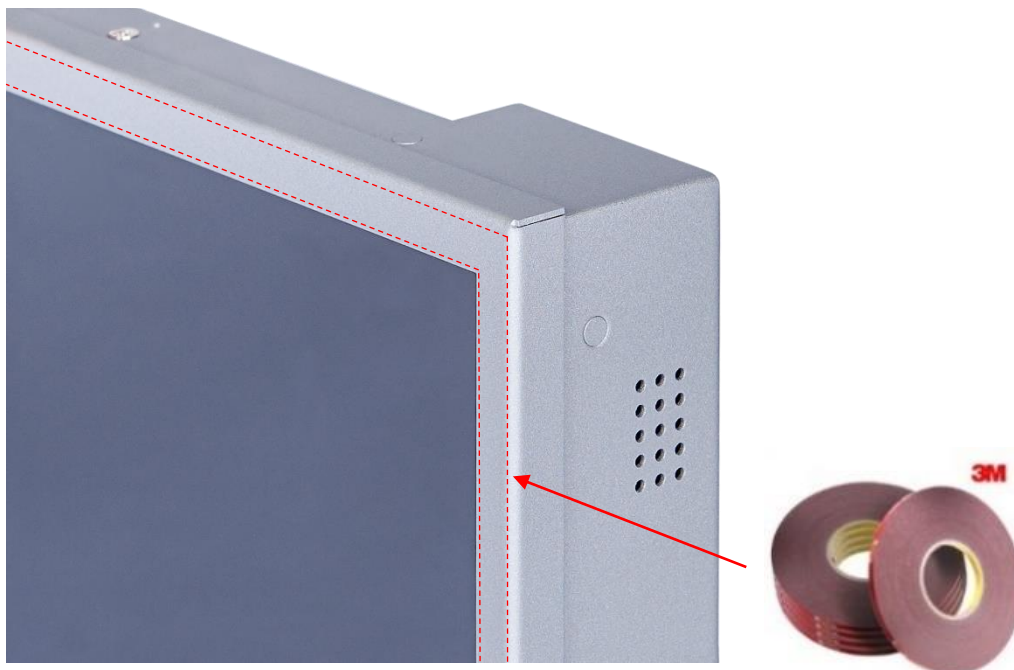

Open-frame Bracket (Option)

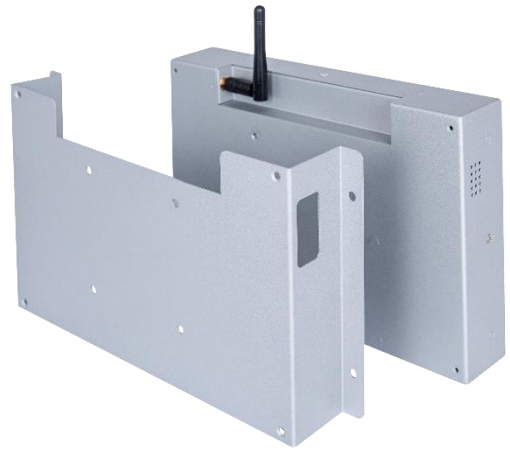
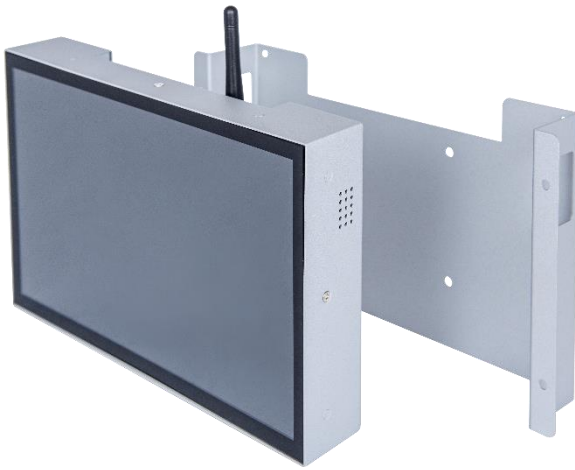
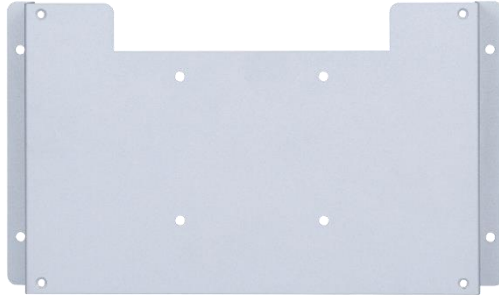

Panel Mount Kits (Option)

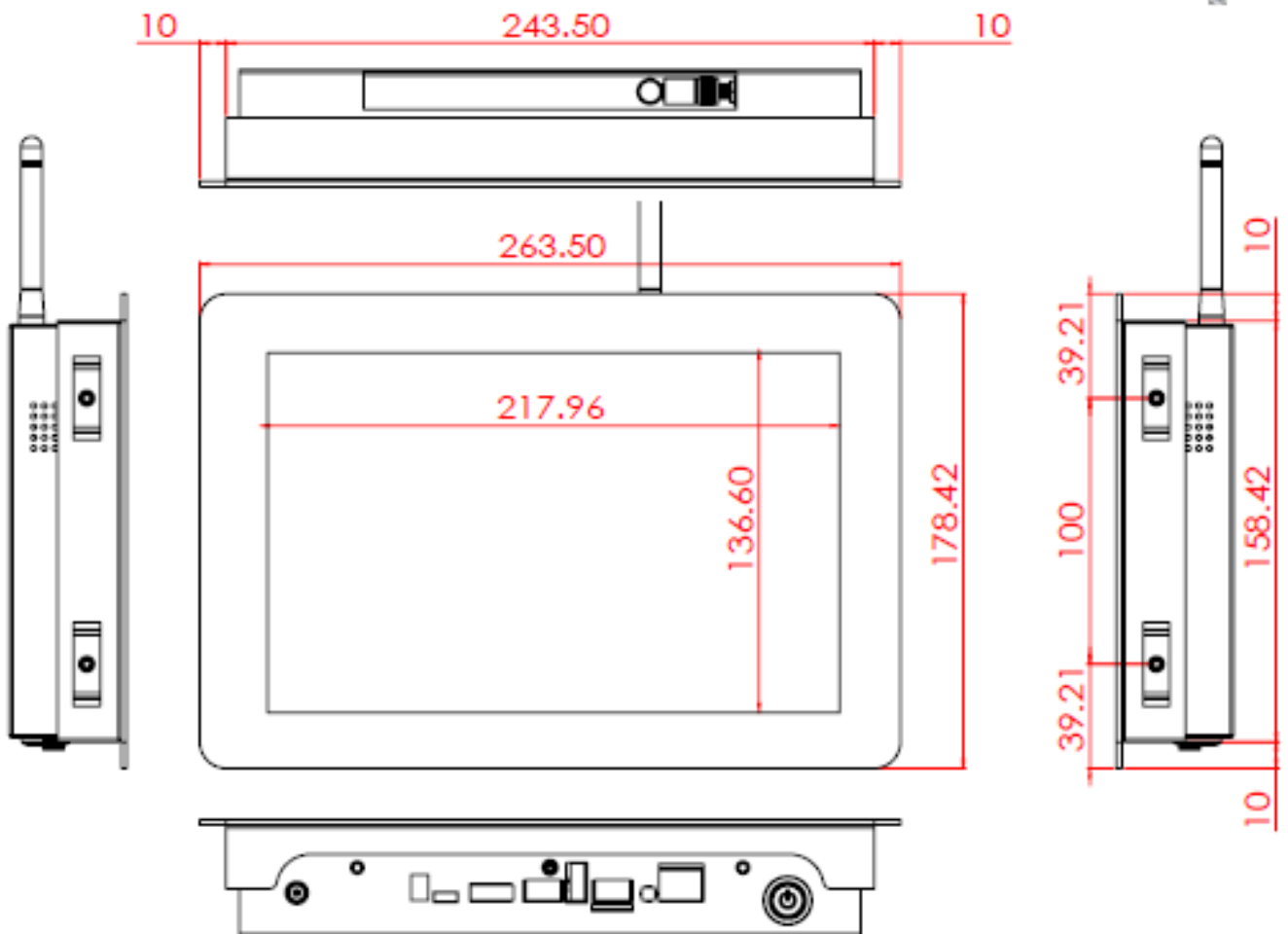

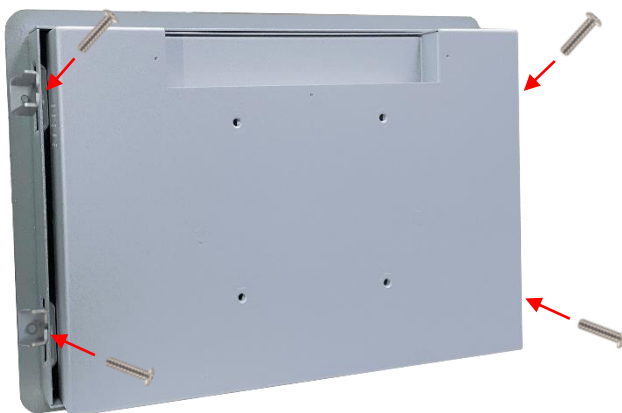
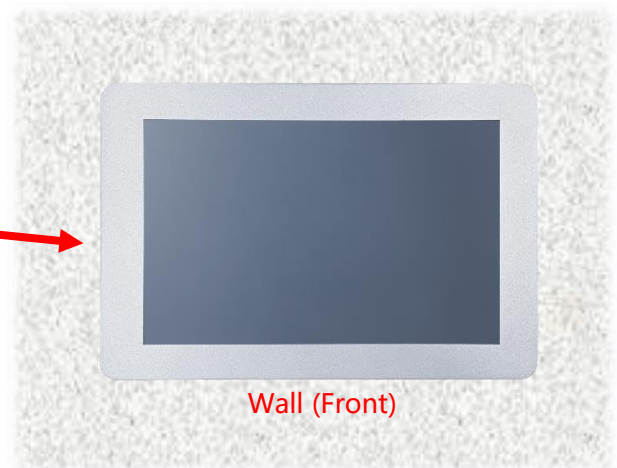
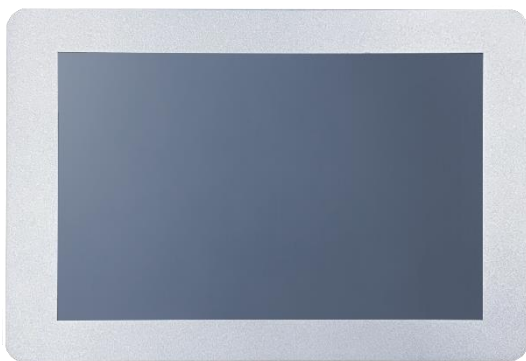
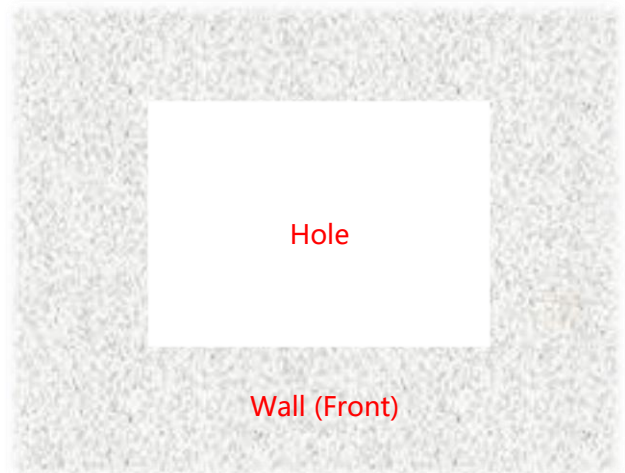
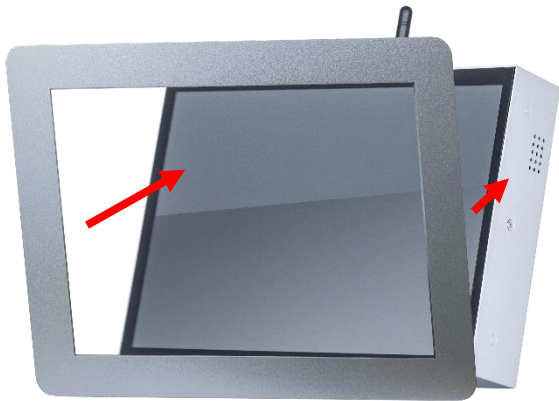

Desktop Stand (Option)

Item	L Stand	Part No.	DST-0B004/DST-1B004
Mounting Pattern	100x100 / 75x75 mm	Dimension (WxHxD)	194x194x222 mm
Material	SECC	Net Weight	1.4 KG
Tilt (Hinge)	105°	Support Max. Weight	15 KG



Item	B Stand	Part No.	DST-0B002/DST-1B002
Mounting Pattern	100x100 / 75x75 mm	Dimension (WxHxD)	203x275x227 mm
Material	Steel/Plastic/Aluminum	Net Weight	1.8 KG
Tilt (Hinge)	-2° ~ +180°	Support Max. Weight	15 KG



Desktop Stand (Option)

Item	Z Stand	Part No.	DST-0BZ01/DST-1BZ01
Mounting Pattern	100x100 / 75x75 mm	Dimension (WxHxD)	190x240x41.6
Material	SECC	Net Weight	2.6 KG
Tilt (Hinge)	±360°	Support Max. Weight	15 KG



Wall Mount Bracket (Option)

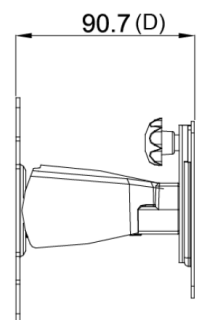
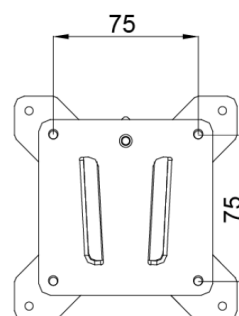
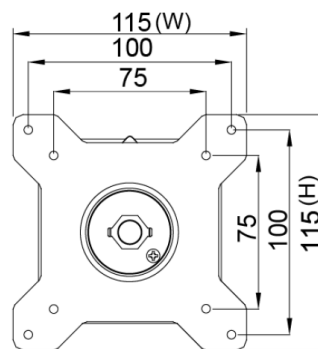
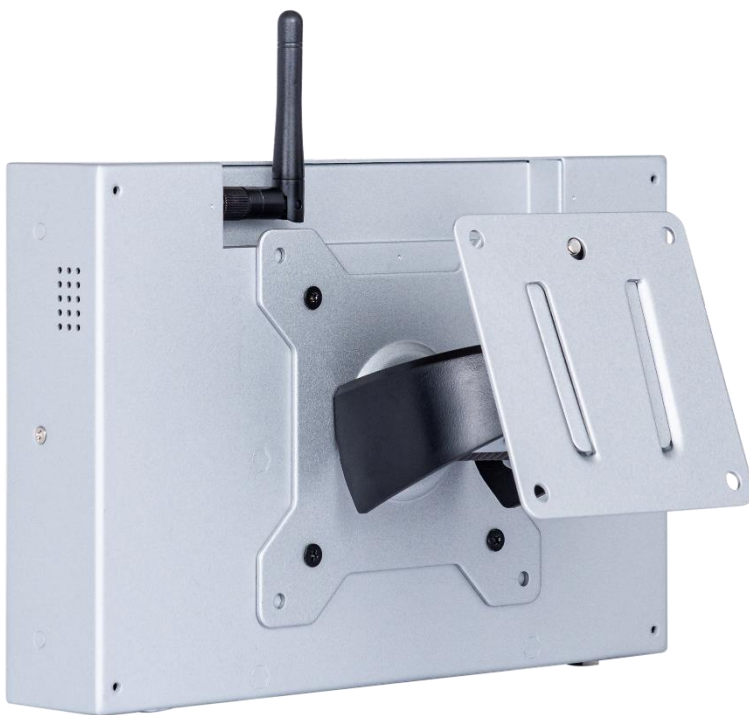

Physical Specifications

Dimension	233.5x155.4x41(±2)mm (W/O Antenna)	Net Weight	≤1.4 KG
VESA Mounting	75x75 mm	Gross Weight	≤2.5 KG

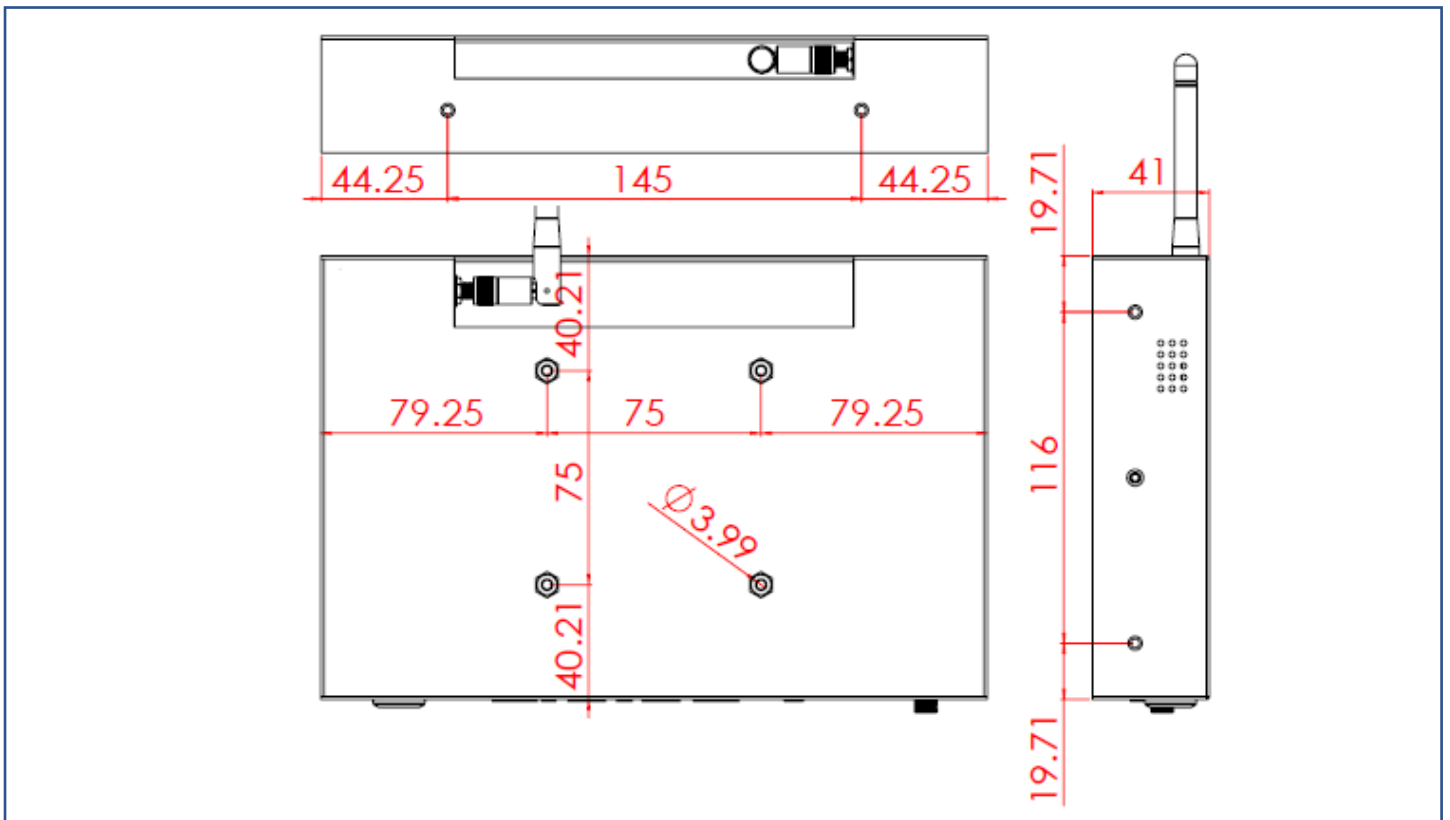
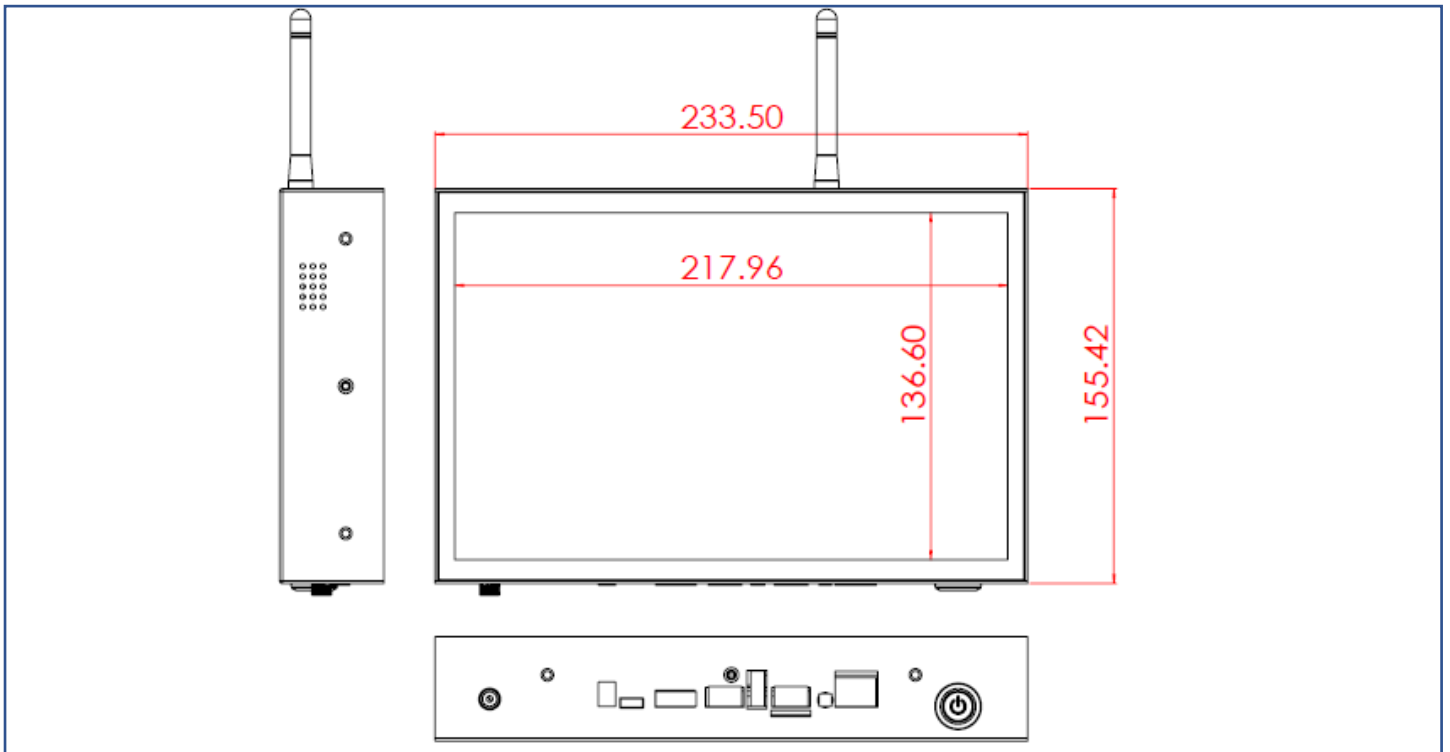

Cosmetic Inspection Standard

Display Area Allowance			
Defect description	Defective Specifications	Allowance	Remarks
Dot Defect (including dark dot, particles, bubbles, pits, dust, foreign matter)	$D \leq 0.2\text{mm}$	Ignored	D=Diameter
	$0.2 < D \leq 0.7\text{mm}$	$N \leq 5$	N=Quantity
	$0.7 < D \leq 1\text{mm}$	$N \leq 3$	
	$D > 1\text{mm}$	$N \leq 0$	
Linear Defect (including scratches, fluff, particles)	$W \leq 0.15\text{mm}$	Ignored	W=Width
	$0.15 < W \leq 0.5\text{mm}, L \leq 15\text{mm}$	$N \leq 2$	L=Length
	$W > 0.5\text{mm}$ or $L > 15\text{mm}$	NG	

* Visual inspection distance: 60cm, 90 degree (same for front/side/back)

Front Appearance Allowance (Including Coating)			
Defect description	Defective Specifications	Allowance	Remarks
Dot Defect (including particles, bubbles, pits...etc.)	$D \leq 0.7\text{mm}$	Ignored	D=Diameter
	$0.7 < D \leq 1.5\text{mm}$	$N \leq 3$	N=Quantity
	$D > 1.5\text{mm}$	$N \leq 0$	
Linear Defect (including scratches, fluff, particles)	$W \leq 0.2\text{mm}, L \leq 15\text{mm}$	Ignored	W=Width, L=Length
	$0.2 < W \leq 0.7\text{mm}, L \leq 15\text{mm}$	$N \leq 1$	
	$W > 0.7\text{mm}$ or $L > 15\text{mm}$	NG	

Side / Back Appearance Allowance (Including Coating)			
Defect description	Defective Specifications	Allowance	Remarks
Dot Defect (including particles, bubbles, pits...etc.)	$D \leq 1.5\text{mm}$	Ignored	D=Diameter
	$1.5 < D \leq 3\text{mm}$	$N \leq 8$	N=Quantity
	$D > 3\text{mm}$	$N \leq 2$	
Linear Defect (including scratches, fluff, particles)	$W \leq 0.8\text{mm}, L \leq 15\text{mm}$	Ignored	W=Width, L=Length
	$0.8 < W \leq 1.5\text{mm}, L \leq 15\text{mm}$	$N \leq 5$	
	$W > 1.5\text{mm}$ or $L > 15\text{mm}$	NG	

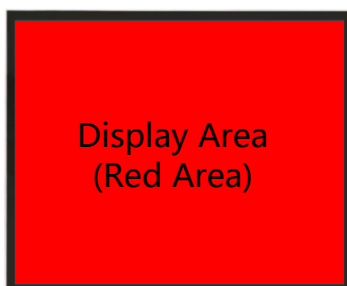

Display Area
(Red Area)



Front Appearance (Red Area)



Back Appearance